

March

Revision 1

2017 CATALOG



MoTeC Systems USA

5355 Industrial Drive

Huntington Beach, CA 92649

Phone 1.800.845.7580

Fax 1.714.897.8782

sales@motec.com

MoTeC Systems East

169-5 Gasoline Alley

Mooresville, NC 28117

Phone 1.704.799.3800

Fax 1.704.799.3874

sales@moteceast.com



www.motecusa.com

Motec Systems West



Optimal performance begins here. Stop by and see us in Huntington Beach. We've been providing the best in engine management systems and support since 1985.



**5355 Industrial Drive
Huntington Beach, CA 92649
(714) 895-7001**

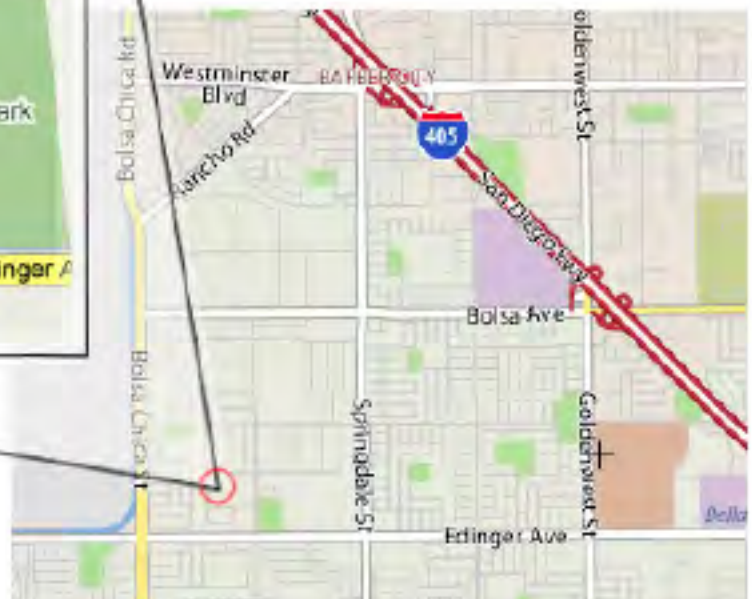

***Business Hours:
Monday - Friday
8:30am - 5:00pm***

Motec Systems East



**169-5 Gasoline Alley
Mooresville, NC 28117
(704) 799-3800**

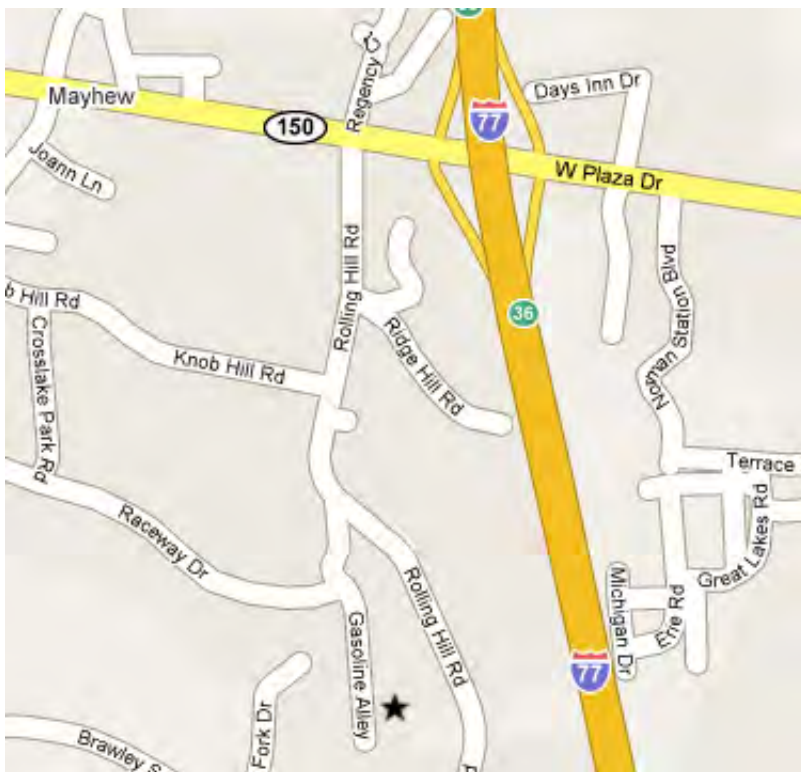

**Business Hours:
Monday - Friday
8:30am - 5:00pm**

Table Of Contents

<i>Motec Systems West</i>	2
<i>Motec Systems East</i>	3
Engine Control Units	8
<i>M1 Series ECU's</i>	9
<i>M1 Series ECU's con'd</i>	10
<i>M1 Series Hardware Comparison Chart</i>	11
<i>M84</i>	12
<i>M400</i>	13
<i>M600</i>	14
<i>M820</i>	15
<i>M880</i>	16
<i>M800 Plug-In ECUs</i>	17
<i>PWC Plug-in ECU's</i>	18
<i>Snowmobile Plug-In ECU's</i>	19
<i>MoTeC ECU Options</i>	20
<i>MoTeC ECU Comparison Chart</i>	21
Displays	22
<i>MoTeC D1 Series Color Displays</i>	23
M D153	23
<i>MoTeC D1 Series Color Displays</i>	24
M D175	24
Display Loggers	25
<i>MoTeC C1 Series Color Display Loggers</i>	26
M C125 USB	26
C125 USB Upgrades	26
<i>MoTeC C1 Series Color Display Loggers</i>	27
M C127 USB	27
C127 USB Upgrades	27
<i>MoTeC C1 Series Color Display Loggers</i>	28
M C185 USB	28
C185 USB Upgrades	28
<i>MoTeC C1 Series Color Display Loggers</i>	29
M C187 USB	29
C187 USB Upgrades	29

M1212 USB	30
M1212 USB Upgrades	30
M1812 USB	31
M1812 USB Upgrades	31
Club Dash Logger 3 (CDL3)	32
Accessory Kit	32
CDL3 Upgrades.....	32
Loggers	33
MoTeC L1 Series Enclosed Loggers	34
M L120	34
MoTeC L1 Series Enclosed Loggers	35
M L120 USB.....	35
MoTeC L1 Series Enclosed Loggers	36
M L180	36
Advanced Central Logger (ACL)	37
ACL Upgrades.....	37
Data Logger Chart	38
Lights	39
Billet Shift / Warning Indicator	40
Video	41
MoTeC V2 Video Kit	42
Video Sync Module (VSM)	43
Expansion Boxes	44
Synchronous Versatile Input Module (SVIM)	45
E888 / E816	46
Ignition Expander	47
Traction Control Multiplexer	48
Lambda	49
Lambda To CAN (LTC)	50
Lambda To CAN Dual (LTCD)	51
Lambda To CAN (LTC NTK)	52
Lambda To CAN Dual (LTCD NTK)	53
Professional Lambda Meter (PLM)	54
Professional Lambda Meter Accessories.....	54

Power.....	55
<i>PDM16</i>	56
<i>PDM32</i>	57
<i>PDM15</i>	58
<i>PDM30</i>	59
<i>Dual Half Bridge (DHB)</i>	60
Ignition.....	61
<i>Capacitive-Discharge Ignitions</i>	62
Multi Coil Inductive	62
Capacitive-Discharge Coils	62
Capacitive-Discharge Ignitions Accessories.....	62
CDI-8 Wiring.....	62
<i>Capacitive-Discharge Ignitions Accessories</i>	63
Coil Near Plug Inductive	63
Denso Termination.....	63
<i>RaceGrade High Output Ignition Coil (IGN1A)</i>	64
<i>Multi-Channel Ignitors</i>	65
Lap Timing	66
<i>BR2 Receiver</i>	67
<i>BTX Transmitter</i>	68
<i>MoTeC GPS</i>	69
<i>RaceGrade GPS Radio</i>	70
Sensors.....	71
<i>Temperature Sensors</i>	72
Air Temp.....	72
Liquid Temp.....	72
Head Temp	72
Exhaust Temp	72
<i>Crank & Speed Sensors</i>	73
Crank/Cam Trigger	73
Dual Magnetic Converter	73
Wheel Speed	73
<i>Position Sensors</i>	74
String Potentiometers	74
Fluid level	74

Linear Position	74
Throttle Angle	74
Pressure Sensors.....	75
MoTeC.....	75
RaceGrade Autosport.....	75
RaceGrade DTM.....	75
Lambda Sensors.....	76
RaceGrade TC8 Thermocouple to CAN.....	77
Switches	78
Communication	80
Ethernet	81
Motorsport Ethernet Switch	81
CAN Adaptors	82
USB To CAN Adaptor (UTC)	82
Serial to CAN Adaptor (STC)	82
Trim Switches	83
Steering-Wheel Switch Assembly.....	83
Dashboard Mounted.....	83
Comm Cables ECU-PC.....	84
Communications Cable for M48 / M8.....	84
Communications Cable for M4E / M800 / M880	84
Communications Cable for M48 / M8 with ADL	84
PC parallel-to-CAN cable	84
Computer Interface Module	84
Crimpers.....	85
Extractors.....	88
Boots.....	90
Rubber.....	91
Vinyl.....	91
Connector Kits	92
MAP Sensor	93
Weather-Pack.....	94
Metripack.....	95
Miscellaneous.....	96

<i>Bosch Sensor Kits</i>	97
<i>Injector Kits</i>	98
<i>DTM Kits</i>	99
<i>DT/DTP Kits</i>	100
<i>Autosport Connectors</i>	101
<i>Type 0 Micro Series</i>	102
<i>Type 1 Micro Series</i>	103
<i>Type 6 Micro Series</i>	104
<i>Type 0 AS Series</i>	105
<i>Type 1 AS Series</i>	106
<i>Type 2 AS Series</i>	107
<i>Type 6 AS Series</i>	108
<i>Apparel</i>	109
<i>Support</i>	111
<i>On-Site</i>	112
<i>Phone</i>	112
<i>Track</i>	112
<i>Glossary</i>	113

Engine Control Units

M1 Series ECU's

Advances in technology have increased the demands on a vehicle's components, especially the ECU. This demand has reached the point where a single firmware to ECU configuration cannot meet the market's ECU requirements (even with increased capacity and processor speed).

The M1 series was conceived by MoTeC to overcome this one-to-one, firmware to ECU limitation, by designing a system where operational efficiency, advanced features and flexibility are its primary objectives. At its core, M1 provides the ability to develop a suite of flexible and tailored solutions (packages), making it ideal for any application (however complex) and category management.



Key advantages of M1 systems:

- Latest generation high performance processor
- Large logging memory, fast Ethernet downloads
- Compact and lightweight in robust magnesium enclosures
- Supports direct injection and port injection applications
- Supports advanced logging features including Pro Analysis (i2 Pro)
- Advanced security system, incorporating an anti-tampering microprocessor
- Access log-in levels for multiple users
- Suitable for modern engines with DBW, Cam Control and multiple CAN buses
- Advanced logging features, high speed, multiple logs (with access logins)
- I/O expansion using E816, E888 expanders
- Flexible tuning software
- Programmable digital input system for Ref/Sync, wheel speeds etc.
- Programmable trigger levels, diagnostics
- All Low Side and Half Bridge outputs have PWM capability

MOTEC'S DISTINCTIVE RANGE OF M1 ECU SOLUTIONS

Targeted Solutions - We've done the configuration work for you, tailoring the ECU firmware to a specific vehicle or engine. In some cases this includes integration with vehicle control systems beyond the engine, for example, stability control, cruise control. Complete Plug-In kits are available for some applications, including any additional hardware and wiring looms as required. See targeted solutions for Vehicle, Bike, PWC or Snowmobiles

GP (General Purpose) Solutions - MoTeC's GP Solutions offer the flexibility to suit numerous port and direct injected gasoline engines. Comprising of:

- GPA (Advanced)
- GPR (Race)
- GPRP (Race with Paddle shift)
- GPRDI (Race with Direct Injection)
- GPRPDI (Race with Paddle Shift and Direct Injection)

These variants that can be configured to suit a wide range of applications.

Development Solutions - Those who are skilled at coding can now develop fully customised control strategies at the firmware level, creating unique ECU functionality for themselves or other customers. Developers can build custom controls into an existing package, or create a new project from scratch. In either instance, the resulting firmware can be loaded into a single Development ECU or rolled out for customers around the world to purchase.

Ruggedised - Sometimes an extra level of protection for electronic components is required, such as marine applications or environments subject to dirt or dust. Our Ruggedised M1 hardware ensures maximum longevity under these extreme conditions.

M130



M150



M170



M190



M142



M182



M1 Series ECU's con'd

MoTeC's M1 ECU range begins a new era in engine control meaning of customisation, delivering total control without compromise. Highly advanced security strategies make these ECUs ideal for both category managed and unrestricted applications.

The M142 and M182 are Diesel / Direct Injector ECUs that offer full control for most modern high pressure injectors, without the need for additional amplifier boxes.

FEATURES

- Small and light in robust magnesium enclosure
- Port injection injector type (M130, M150, M170, M190)
- Diesel and Direct injection control without the need for an external controller (M142, M182)
- Large logging memory
- Latest generation high performance processor
- Suitable for modern engines with DBW, Cam Control and multiple CAN buses
- Advanced logging features, high speed, multiple logs (with access logins)
- I/O expansion using E816, E888 expanders
- Flexible tuning software
- Robust and comprehensive security features
- Programmable injector drive characteristics
- Programmable digital input system for Ref/Sync, wheel speeds etc.
- Programmable trigger levels, diagnostics
- All Low Side and Half Bridge outputs have PWM capability

CONFIGURATION

The M1 series ECUs come with three configuration options.

Locked Configuration

A locked configuration is appropriate when an ECU contains specific firmware to suit the application. The user can tune the engine in the normal way but the ECU can not be re-configured for another application.

Standard Configuration

The standard configuration allows the user to load a selection of firmware packages available from MoTeC. They incorporate different levels of functionality and the user can choose one to suit their requirements. Additional packages can be loaded into the ECU as and when requirements change.

Open Configuration

The open configuration provides a fully flexible ECU solution that can be precisely tailored to individual requirements. Third party developers can be trained to use MoTeC M1 Build software to develop their own control strategies. Intellectual property is protected by the M1 ECU's security system. and remains with the ECU owner.

SECURITY

The M1's advanced security system is based on public-key cryptography, the cornerstone of secure internet transactions, so it is virtually impossible to change the ECU function without authorised permission.

Security is enforced by the ECU and protected by a microprocessor with integrated measures to prevent tampering.

A password feature grants different levels of access for different users e.g. an engine tuner, a drive train tuner, and a data analysis engineer.

This is also suitable for Control ECUs. Scrutineering teams can have access to extra information and are able to lock down selected parts of the ECU, while other team members can access selected tuning parameters.

CATEGORY MANAGEMENT

The combination of an advanced security strategy, configurable firmware and a high performance processor make the M1 ECU an ideal choice for categories with restrictions in place for either performance parity or cost containment. Firmware can be written specifically for the category, limiting the functionality to the class requirements.

Multiple data logging sets are available, which can be partitioned with restricted access to allow generation of both judicial (scrutineering) and team data from the same device. The M1 ECU's security system prevents unauthorised access to data and implementation of unspecified functionality.

UPGRADES

- Various Logging Options are available. The logging licence determines the number of channels and the sample rates available, there are 3 levels available:
 - **Logging Level 1 Licence**
Comes standard with the product. This diagnostic logging includes a fixed log set and rate.
 - **Logging Level 2 Licence**
Is an optional upgrade which includes one fixed log set, 200 channels (including diagnostics) and a maximum 200 Hz sample rate.
 - **Logging Level 3 Licence**
Is an optional upgrade which includes eight fixed log sets, 2000 channels and a maximum 1000 Hz sample rate.
- Configuration:
 - Locked Configuration
 - Standard Configuration
 - Open Configuration

SOFTWARE

- Microsoft Windows™ based software
- PC Tuning software 'Tune' - Used to tune fuel and ignition, set up sensors, outputs and available functions
- PC Software 'Build' - Used to create a custom software package with user specific functions

Item Number	Description
M130	M1 ECU 60 POS PLASTIC
M130 M	M1 MARINE ECU 60 POS PLASTIC
M150	M1 ECU 120 POS PLASTIC
M150 M	M1 MARINE ECU 120 POS PLASTIC
M170	M1 ECU 66 POS AUTOSPORT
M190	M1 ECU 136 POS AUTOSPORT
M190 M	M1 MARINE ECU 60 POS PLASTIC
M142	M1 ECU 120 POS PLAS DIRECT INJ
M182	M1 ECU 136 POS AS DIRECT INJ

M1 Series Hardware Comparison Chart

	M130	M150	M170	M190	M142	M182
Injector						
Direct Injector Outputs					8	12
Max hold current (A)					12	12
Injector Voltage (max)					90 V	90 V
Peak & Hold Outputs (can also drive saturated)	8	12	8	12		
Low Side Outputs				12	6	6
Ignition						
Low Side Ignition Outputs (max)	8	12	8	12	8	12
Auxiliary Outputs						
Low Side Output	2	6	2	6	6	6
Half Bridge Output	6	10	6	10	10	10
Inputs						
Universal Digital Input	7	12	8	12	12	12
Digital Input		4		4	4	4
Analog Voltage Input	8	17	8	17	17	17
Analog Temp Input	4	6	4	6	6	6
Lambda (Narrow band)	0	2	0	2	2	2
Data						
CAN Bus/RS232/LIN	1/0/0	3/1/1	1/0/0	3/1/1	3/1/1	3/1/1
Logging Memory (MB)	120	250	250	250	250	250
Physical Size (mm)						
107x127x39 (mm)	✓		✓			
162x127x39 (mm)		✓		✓	✓	✓
Weight (g)	290g	450g	310g	490g	490g	530g
No. of Connectors						
Plastic	2	4			4	
Autosport			1	3		3
Pins	60	120	66	136	120	136

M84

The new MoTeC M84 ECU delivers a unique package of professional-level features at an entry-level price. Designed with the same sophisticated technology that leading motorsport teams trust worldwide, this is intelligent, race proven control with just the right amount of versatility.

Engine Tuning Features

Windows based ECU Manager tuning software with user definable screen layouts

Individual cylinder tuning of both fuel delivery and ignition timing

Suits modern engines, including those with coil per cylinder ignition

Fully configurable axis points on all tables

Highly configurable crank and cam trigger inputs to suit almost all OEM sensors and tooth patterns

Single Wideband Lambda input (dual optional)

Additional Distinct Features

Capable of advanced control functions, such as:

- Traction control
- Overrun boost enhancement (anti-lag)
- Gear change ignition cut (flat shift)
- Boost control
- **NEW:** Nitrous injection
- Dual stage injection (Hi/Lo injection)

Configurable sensor inputs including custom calibrations

Capable of receiving and transmitting data via the CAN bus

Capable of receiving data from two Lambda measurement devices via CAN

Integrated advanced diagnostics, including injector and crank trigger diagnostics

Ref/Sync capture displayed on the built-in digital oscilloscope

Data Acquisition

Internal data logging (512 kB) with fast download via CAN

State of the art i2 Standard data analysis software

Now with 100 Hz max logging rate



Item Number	Description
M84	M84 ECU

Outputs

8 x Injector outputs - high or low ohm

6 x Ignition outputs

8 x Auxiliary outputs - for functions such as boost control, idle speed stepper motor and many more

Inputs

Throttle Position

Manifold Pressure

Mass Air Flow

Fuel Pressure

Oil Pressure

Exhaust Temperature

Gear Position

User 1

Air Temperature

Coolant Temperature

User 2

3 x Switched Analogue Temperature

2 x Lambda Inputs (supports Wideband and Narrowband sensors)

4 x Digital Inputs (wheel speed or switch)

Communications

1 x CAN

1 x RS232

Physical

Case size 147 x 105 x 40 mm

Weight 500 grams

1 x 34 pin and 1 x 26 pin waterproof connector with gold plated contacts

M400

Developed with the same advanced technology as our revolutionary M800 and M880 models, the MoTeC M400 reflects the demand for sophisticated electronics to control today's highly evolved engines.

Engine Tuning Features

Windows based ECU Manager tuning software with user definable screen layouts

Individual cylinder tuning of both fuel delivery and ignition timing

Suits modern engines, including those with coil per cylinder ignition

4D fuel and ignition tables for engine mapping based on three channels ‡

Fully selectable input channels for all tables, including internal channels ‡

Fully configurable axis points on all tables ‡

Highly configurable crank and cam trigger inputs to suit almost all OEM sensors and tooth patterns

Free access to Wideband Lambda and data logging for initial tuning. Available for the first 8 hours of engine running time

Additional Distinct Features

Suitable for engines requiring the latest complex control functions, such as:

- Continuously variable camshaft control (up to 2 inlet and 2 exhaust cams)
- Drive by Wire throttle control

Capable of all other modern control functions, such as:

- Traction control
- Overrun boost enhancement (anti-lag)
- Gear change ignition cut (flat shifts)
- Boost control
- Nitrous injection
- Dual stage injection (Hi/Lo injection)

Fully configurable sensor inputs including custom calibrations

Configurable receiving and transmitting data via the CAN bus

Capable of receiving data from multiple Lambda measurement devices via CAN

Integrated advanced diagnostics, including injector & crank trigger diagnostics

Switchable between multiple configurations ‡

Ref/Sync capture displayed on the built-in digital oscilloscope ‡

Data Acquisition

Internal data logging (512 kB) with fast download via CAN

Three engine histogram logs including a tell-tale log ‡

State of the art i2 Standard or i2 Pro data analysis software

Upgradable with optional functionality to make additional features

available when you want them, activated through a simple password system.



Item Number	Description
M400	M400 ECU

Outputs

4 x Injector outputs—high or low ohm

4 x Ignition outputs

8 x Auxiliary outputs—for functions such as camshaft control, drive by wire throttle, boost control, nitrous injection, idle speed stepper motor and many more

Inputs

8 x Analogue voltage inputs—fully configurable including custom calibrations

6 x Analogue temperature inputs—fully configurable including custom calibrations

1 x Wideband Lambda input—for Lambda measurement and control

4 x Digital/speed inputs—for wheel speeds and function activation

Communications

1 x CAN

1 x RS232

Physical

Case size 147 x 105 x 40 mm

Weight 500 gram

1 x 34 pin and 1 x 26 pin waterproof connector with gold plated contacts

‡ Only available with Version 3 software

M600

Developed with the same advanced technology as our revolutionary M800 and M880 models, the MoTeC M600 reflects the demand for sophisticated electronics to control today's highly evolved engines.

Engine Tuning Features

Windows based ECU Manager tuning software with user definable screen layouts

Individual cylinder tuning of both fuel delivery and ignition timing

Suits modern engines, including those with coil per cylinder ignition

4D fuel and ignition tables for engine mapping based on three channels ‡

Selectable channels for table axes ‡

Fully configurable axis points on all tables ‡

Highly configurable crank and cam trigger inputs to suit almost all OEM sensors and tooth patterns

Free access to wideband Lambda and data logging for initial tuning. Available for the first 8 hours engine running time

Additional Distinct Features

Suitable for engines requiring the latest complex control functions, such as:

- Continuously variable camshaft control (up to 2 inlet and 2 exhaust cams)
- Drive by wire throttle control

Capable of all other modern control functions, such as:

- Traction control
- Overrun boost enhancement (anti-lag)
- Gear change ignition cut (flat shifts)
- Boost control
- Nitrous injection
- Dual stage injection (Hi/Lo injection)

Fully configurable sensor inputs including custom calibrations

Configurable receiving and transmitting data via the CAN bus

Capable of receiving data from multiple Lambda measurement devices via CAN

•ntegrated advanced diagnostics, including injector & crank trigger diagnostics

Switchable between multiple configurations ‡

Ref/Sync capture displayed on the built-in digital oscilloscope ‡

Data Acquisition

Internal data logging (512 kB) with fast download via CAN

Three engine histogram logs including a tell-tale log ‡

State of the art i2 Standard or i2 Pro data analysis software

Upgradable with optional functionality to make additional features

available when you want them, activated through a simple password system.



Item Number	Description
M600	M600 ECU

Outputs

6 x Injector outputs—high or low ohm

6 x Ignition outputs

8 x Auxiliary outputs—for functions such as camshaft control, drive by wire throttle, boost control, nitrous injection, idle speed stepper motor and many more

Inputs

8 x Analogue voltage inputs—fully configurable including custom calibrations

6 x Analogue temperature inputs—fully configurable including custom calibrations

2 x Wideband Lambda inputs—for Lambda measurement and control

4 x Digital/speed inputs—for wheel speeds and function activation

Communications

1 x CAN

1 x RS232

Physical

Case size 147 x 105 x 40 mm

Weight 500 gram

1 x 34 pin and 1 x 26 pin waterproof connector with gold plated contacts

‡ Only available with Version 3 software

M820

The M800 offers the next generation in Engine Management Systems. This system has been developed through rigorous research and practical fieldtesting. The M800 retains all the best features of our previous ECUs, while offering a combination of unsurpassed power and flexibility.

Engine Tuning Features

- Windows based ECU Manager tuning software with user definable screen layouts
- Individual cylinder tuning of both fuel delivery and ignition timing
- Suits modern engines, including those with coil per cylinder ignition
- 4D fuel and ignition tables for engine mapping based on three channels ‡
- Selectable channels for table axes ‡
- Fully configurable axis points on all tables ‡
- Highly configurable crank and cam trigger inputs to suit almost all OEM sensors and tooth patterns
- Free access to wideband Lambda and data logging for initial tuning. Available for the first 8 hours engine running time

Additional Distinct Features

Suitable for engines requiring the latest complex control functions, such as:

- Continuously variable camshaft control (up to 2 inlet and 2 exhaust cams)
- Drive by wire throttle control

Capable of all other modern control functions, such as:

- Traction control
- Overrun boost enhancement (anti-lag)
- Gear change ignition cut (flat shifts)
- Boost control
- Nitrous injection
- Dual stage injection (Hi/Lo injection)

Fully configurable sensor inputs including custom calibrations

Configurable receiving and transmitting data via the CAN bus

Capable of receiving data from multiple Lambda measurement devices via CAN

Integrated advanced diagnostics, including injector & crank trigger diagnostics

Switchable between multiple configurations ‡

Ref/Sync capture displayed on the built-in digital oscilloscope ‡

Data Acquisition

Internal data logging (1 MB) with fast download via CAN

Three engine histogram logs including a tell-tale log ‡

State of the art i2 Standard or i2 Pro data analysis software

Telemetry and remote logging options

Upgradable with optional functionality to make additional features

available when you want them, activated through a simple password system



Item Number	Description
M820	M800 ECU W/ADVANCED FUNCTIONS

Outputs

8 x Injector outputs—high or low ohm ‡

6 x Ignition outputs ‡

Optional injector / ignition configurations:
(requires 10/12 Cylinder Sequential upgrade)

10 high ohm injector outputs / 4 ignition outputs

12 high ohm injector outputs / 2 ignition outputs

8 x Auxiliary outputs—for functions such as camshaft

control, drive by wire throttle, boost control, nitrous

injection, idle speed stepper motor and many more

Inputs

8 x Analogue voltage inputs—fully configurable including custom calibrations

6 x Analogue temperature inputs—fully configurable including custom calibrations

2 x Wideband Lambda inputs—for Lambda measurement and control

4 x Digital/speed inputs—for wheel speeds and function activation

Communications

1 x CAN

1 x RS232

Physical

Case size 147 x 105 x 40 mm

Weight 500 gram

1 x 34 pin and 1 x 26 pin waterproof connector with gold plated contacts

‡ Only available with Version 3 software

M880

The M880 is MoTeC's top of the line ECU. Developed for motorsport professionals, it takes the M800 engineering one step further with an Autosport connector, Advanced Functions‡ as standard and an optional 4 MB logging memory.

Engine Tuning Features

Windows based ECU Manager tuning software with user definable screen layouts
 Individual cylinder tuning of both fuel delivery and ignition timing
 Suits modern engines, including those with coil per cylinder ignition
 4D fuel and ignition tables for engine mapping based on three channels ‡
 Selectable channels for table axes ‡
 Fully configurable axis points on all tables ‡
 Highly configurable crank and cam trigger inputs to suit almost all OEM sensors and tooth patterns
 Free access to wideband Lambda and data logging for initial tuning. Available for the first 8 hours engine running time

Additional Distinct Features

- Suitable for engines requiring the latest complex control functions, such as:
- Continuously variable camshaft control (up to 2 inlet and 2 exhaust cams)
 - Drive by wire throttle control
- Capable of all other modern control functions, such as:
- Traction control
 - Overrun boost enhancement (anti-lag)
 - Gear change ignition cut (flat shifts)
 - Boost control
 - Nitrous injection
 - Dual stage injection (Hi/Lo injection)

Fully configurable sensor inputs including custom calibrations
 Configurable receiving and transmitting data via the CAN bus
 Capable of receiving data from multiple Lambda measurement devices via CAN
 Integrated advanced diagnostics, including injector & crank trigger diagnostics
 Switchable between multiple configurations ‡
 Ref/Sync capture displayed on the built-in digital oscilloscope ‡

Data Acquisition

Internal data logging (1 MB or 4 MB) with fast download via CAN
 Three engine histogram logs including a tell-tale log ‡
 State of the art i2 Standard or i2 Pro data analysis software
 Telemetry and remote logging options
 Upgradable with optional functionality to make additional features available when you want them, activated through a simple password system.



Item Number	Description
M880	M880 ECU

Outputs

8 x Injector outputs—high or low ohm ‡
 6 x Ignition outputs ‡
 Optional injector / ignition configurations:
 (requires 10/12 Cylinder Sequential upgrade)
 10 high ohm injector outputs / 4 ignition outputs
 12 high ohm injector outputs / 2 ignition outputs
 8 x Auxiliary outputs—for functions such as camshaft control, drive by wire throttle, boost control, nitrous injection, idle speed stepper motor and many more

Inputs

8 x Analogue voltage inputs—fully configurable including custom calibrations
 6 x Analogue temperature inputs—fully configurable including custom calibrations
 2 x Wideband Lambda inputs—for Lambda measurement and control
 4 x Digital/speed inputs—for wheel speeds and function activation

Communications

1 x CAN
 1 x RS232

Physical

Case size 147 x 105 x 40 mm
 Weight 525 gram
 1 x 66 pin Autosport connector

‡ Only available with Version 3 software

M800 Plug-In ECUs

These ECUs are designed as plug in boards to replace the OEM computers in a number of high performance late model vehicles. Complete with an OEM connector, they provide the flexibility and performance of a MoTeC M800 ECU without the necessity of rewiring the car or building adaptor looms. They simply plug into the factory wiring harness using the original sensors, ignition modules and fuel system. The units are built to operate with saturated drive fuel injectors.

Engine Tuning Features

Windows based ECU Manager tuning software with user definable screen layouts
 Individual cylinder tuning of both fuel delivery and ignition timing
 Suits modern engines, including those with coil per cylinder ignition
 4D fuel and ignition tables for engine mapping based on three channels ‡
 Selectable channels for table axes ‡
 Fully configurable axis points on all tables ‡
 Highly configurable crank and cam trigger inputs to suit almost all OEM sensors and tooth patterns
 Free access to wideband Lambda and data logging for initial tuning. Available for the first 8 hours engine running time

Additional Distinct Features

Possibility to communicate directly with MoTeC diff controllers for the same vehicles
 Suitable for engines requiring the latest complex control functions, such as:

- Continuously variable camshaft control (up to 2 inlet and 2 exhaust cams)
- Drive by wire throttle control

Capable of all other modern control functions, such as:

- Traction control
- Overrun boost enhancement (anti-lag)
- Gear change ignition cut (flat shifts)
- Boost control
- Nitrous injection

Fully configurable sensor inputs including custom calibrations
 Configurable receiving and transmitting data via the CAN bus
 Capable of receiving data from multiple Lambda measurement devices via CAN
 Integrated advanced diagnostics, including injector & crank trigger diagnostics
 Switchable between multiple configurations ‡
 Ref/Sync capture displayed on the built-in digital oscilloscope ‡

Data Acquisition

Internal data logging (1 MB) with fast download via CAN
 Three engine histogram logs including a tell-tale log ‡
 State of the art i2 Standard or i2 Pro data analysis software
 Telemetry and remote logging options
 Upgradable with optional functionality to make additional features available when you want them, activated through a simple password system.



Item Number	Description
M800-EVO4-7	EVO 4-7 AND EVO 8 RS
M800-EVO 4-8	EVO 4-8
M800-EVO8GSR	EVO-8 GSR
M800-EVO9	EVO 9
M800-EVO X †	EVO X
M800-WRX7	WRX 7/8
M800-WRX9	WRX 9/10

Outputs

4 x Injector outputs
 4 x Ignition outputs
 14 x Auxiliary outputs—for functions such as camshaft control, drive by wire throttle, boost control, nitrous injection, idle speed stepper motor and many more

Inputs

8 x Analogue voltage inputs—fully configurable including custom calibrations
 6 x Analogue temperature inputs—fully configurable including custom calibrations
 2 x Wideband Lambda inputs—for Lambda measurement and control
 4 x Digital/speed inputs—for wheel speeds and function activation

Communications

1 x CAN
 1 x RS232

Physical

Board sizes to fit into the OEM ECU enclosure
 Connector to match OEM connector

‡ Only available with Version 3 software

† Special Orders Only

PWC Plug-in ECU's

MoTeC PWC Plug-In ECUs are fully programmable, direct replacements for factory ECUs on a select number of popular PWC models. The kits are based around an M400 Marine ECU which is fully polyurethane-potted, making it specifically suited to the watercraft environment. Complete with a wiring loom and mounting brackets, simply plug into the factory wiring harness using the original sensors and fuel system.

Engine Tuning Features

- Windows based ECU Manager tuning software with user definable screen layouts
- Individual cylinder tuning of both fuel delivery and ignition timing
- Suits modern engines, including those with coil per cylinder ignition
- 4D fuel and ignition tables for engine mapping based on three channels
- Selectable channels for table axes
- Fully configurable axis points on all tables
- Highly configurable crank and cam trigger inputs to suit almost all OEM sensors and tooth patterns
- Free access to wideband Lambda and data logging for initial tuning.

Additional Distinct Features

- Possibility to communicate directly with OEM Dash
- Suitable for engines requiring the latest complex control functions, such as:
 - Continuously variable camshaft control (up to 2 inlet and 2 exhaust cams)
 - Drive by wire throttle control

Capable of all other modern control functions, such as:

- Launch control
- Overrun boost enhancement (anti-lag)
- Boost control
- Nitrous injection

Fully configurable sensor inputs including custom calibrations
 Configurable receiving and transmitting data via the CAN bus
 Capable of receiving data from multiple Lambda measurement devices via CAN

Integrated advanced diagnostics, including injector & crank trigger diagnostics

Switchable between multiple configurations

Ref/Sync capture displayed on the built-in digital oscilloscope

Data Acquisition

Internal data logging (500 kB) with fast download via CAN
 Three engine histogram logs including a tell-tale log
 State of the art i2 Standard or i2 Pro data analysis software
 Telemetry and remote logging options
 Upgradable with optional functionality to make additional features available when you want them, activated through a simple password system.



Outputs

- 4 x Injector outputs—high or low ohm
- 4 x Ignition outputs
- 8 x Auxiliary outputs—for functions such as drive by wire throttle, boost control, nitrous injection, idle speed stepper motor and many more

Inputs

- 8 x Analogue voltage inputs—fully configurable, use for e.g.:
 - jet outlet pressure
 - jet intake pressure
 - steering position
 - lateral G force
- 6 x Analogue temperature inputs—fully configurable, use for :
 - multiple configuration maps
 - extra air or water temperature
 - exhaust temperature
- 1 x Wideband Lambda input—for Lambda measurement and control
- 4 x Digital/speed inputs—for use with OEM factory speed paddle wheel and function activation e.g. launch control, anti lag and dual RPM limit

Communications

- 1 x CAN
- 1 x RS232—for use with GPS
- A 5 Hz MoTeC GPS-L5 can be wired direct to the M400 for logging of accurate speed and position.

Physical

- Case size 147 x 105 x 40 mm
- Weight 900 gram
- 1 x 34 pin and 1 x 26 pin waterproof connector with gold plated contacts

Item Number	Description
M400 YAMAHA	MARINE ECU W/YAMAHA ADAPTOR
M400 KAWASAKI	MARINE ECU W/KAWASAKI ADAPTOR
M400 SEADOO	MARINE ECU W/SEADOO ADAPTOR
M400 HYDROSPACE	MARINE ECU W/HYDROSPACE ADAPTOR

Snowmobile Plug-In ECU's

MoTeC PWC Plug-In ECUs are fully programmable, direct replacements for factory ECUs on a select number of popular PWC models. The kits are based around an M400 Marine ECU which is fully polyurethane-potted, making it specifically suited to the watercraft environment. Complete with a wiring loom and mounting brackets, simply plug into the factory wiring harness using the original sensors and fuel system.

Engine Tuning Features

Windows based ECU Manager tuning software with user definable screen layouts
Individual cylinder tuning of both fuel delivery and ignition timing
Suits modern engines, including those with coil per cylinder ignition
4D fuel and ignition tables for engine mapping based on three channels
Selectable channels for table axes
Fully configurable axis points on all tables
Highly configurable crank and cam trigger inputs to suit almost all OEM sensors and tooth patterns
Free access to wideband Lambda and data logging for initial tuning.
Available for the first 8 hours engine running time

Additional Distinct Features

Possibility to communicate directly with OEM Dash
Suitable for engines requiring the latest complex control functions, such as:

- Continuously variable camshaft control (up to 2 inlet and 2 exhaust cams)
- Drive by wire throttle control

Capable of all other modern control functions, such as:

- Traction control
- Overrun boost enhancement (anti-lag)
- Boost control
- Nitrous injection

Fully configurable sensor inputs including custom calibrations
Configurable receiving and transmitting data via the CAN bus
Capable of receiving data from multiple Lambda measurement devices via CAN
Integrated advanced diagnostics, including injector & crank trigger diagnostics
Switchable between multiple configurations
Ref/Sync capture displayed on the built-in digital oscilloscope

Data Acquisition

Internal data logging (500 kB) with fast download via CAN
Three engine histogram logs including a tell-tale log
State of the art i2 Standard or i2 Pro data analysis software
Telemetry and remote logging options
Upgradable with optional functionality to make additional features available when you want them, activated through a simple password system.
Available for the following crafts:

Yamaha - Apex 2006-10, RTX, RTX ER, GT, ER, LTX, LTX GT and MTX
SkiDoo - 2009-Current, MXZ, MXZ-X, Renegade, Renegade X, GSX



Outputs

4 x Injector outputs—high or low ohm
4 x Ignition outputs
8 x Auxiliary outputs—for functions such as drive by wire throttle, boost control, nitrous injection, idle speed stepper motor and many more

Inputs

8 x Analogue voltage inputs—fully configurable, use for:
-throttle position
-manifold pressure
-exhaust temperature
-steering position
-lateral G force
6 x Analogue temperature inputs—fully configurable, use for:
-multiple configuration maps
-extra air or water temperature
1 x Wideband Lambda input—for Lambda measurement and control
4 x Digital/speed inputs—for use with OEM factory buttons and function activation e.g. launch control, anti lag and dual RPM limit

Communications

1 x CAN
1 x RS232—for use with GPS
A 5 Hz MoTeC GPS-G1 can be wired direct to the M400 for logging of accurate speed and position.

Physical

Case size 147 x 105 x 40 mm
Weight 900 gram
1 x 34 pin and 1 x 26 pin waterproof connector with gold plated contacts

Item Number	Description
M400 SKI-DOO KIT	SKI-DOO 2009 REV-XR
M400 YAMAHA APEX	YAMAHA APEX 2006-9

MoTeC ECU Options

✓ = Available

Description	OEM	M84	M400	M600	M820	M880
Hours free logging & wideband lambda	8		8	8	8	8
M880 512K LOG (Logging 512K)			✓	✓		
M880 1MLOG (Logging 1MB)	✓				✓	✓
M880 4M LOG (Logging 4MB (Must have Logging 1MB))						✓
M880 1LA (Single Wideband Lambda)	✓		✓	✓	✓	✓
M880 1-2LA (Upgrade Single to Dual Wideband Lambda)	✓			✓	✓	✓
M880 2LA (Dual Wideband Lambda)	✓			✓	✓	✓
M880 ADV (Advanced Function (Launch Control/Traction Control (2, 3, or 4 Wheel), Gear Change Ignition Cut (flat shifts), Overrun Boost Enhancement (anti-lag)))	✓		✓	✓	✓	✓
M880 CAM (Cam Control)	✓		✓	✓	✓	✓
M880 DBW EN (Drive By Wire)			✓	✓	✓	✓
M880 ORB ³ (Overrun Boost Enhancement)	✓		✓	✓	✓	✓
M880 10/12 EN (10/12 Cycle Operation)					✓	✓
M880 MULTI PU (Multipulse / Multispark)					✓	✓
M880 PRO ANALYS (Pro Analysis (Multiple Overlays, Advanced Math Functions, Unlimited Projects, Display Components, Workbooks and Worksheets, Damper Analysis, Synchronised Video))	✓				✓	✓
M880 REM LOG (Remote Logging (Requires Telemetry))					✓	✓
M880 SERVO ENAB (Servo Control)					✓	✓
M880 TELEM (Telemetry)					✓	✓
M84 1-2LA (Upgrade Single to Dual Wideband Lambda)		✓				
M84 ADV (Advanced Function (Launch Control/Traction Control (2, 3, or 4 Wheel), Hi/Lo Injection (secondary injection), Gear Change Ignition Cut (flat shifts), Overrun Boost Enhancement (anti-lag)))		✓				
M84 GEAR CHANGE ² (Gear Change Ignition Cut (flat shifts))		✓				
M84 HI-LO INJ ² (Hi/Lo Injection (secondary injection))		✓				
M84 ORB ² (Overrun Boost Enhancement)		✓				
M84 TRAC CNTRL ² (Launch Control/Traction Control (2, 3, or 4 Wheel))		✓				

MoTeC ECU Comparison Chart

These are the main specifications of the MoTeC ECU range to compare the suitability of the different models for your application.

✓ standard available

✗ not available

option - requires optional upgrade

ECU Comparison Table	M84	M400	M600	M800	M880
Number of cylinders					
Sequential	up to 8	up to 4	up to 6	up to 8 opt 12	up to 8 opt 12
Group fire mode	up to 8	up to 4	up to 6	up to 12	up to 12
Rotary	2,3,4	2	2,3	2,3,4	2,3,4
Outputs					
Injector outputs	8	4	6	8*	8*
Ignition outputs	6	4	6	6*	6*
Auxiliary outputs	8	8	8	8	8
Option to use spare outputs as auxiliary outputs	✗	✗	✗	✓	✓
Individual cylinder tables	✗	✓	✓	✓	✓
Inputs					
Trigger inputs (Ref/Sync)	2	2	2	2	2
Analogue voltage inputs	8	8	8	8	8
Analogue temperature inputs	3	6	6	6	6
Digital/speed inputs	4	4	4	4	4
Wideband Lambda inputs (option)	2 x 5-wire (single included, dual option)	1 x 5-wire (option)	2 x 5-wire (option)	2 x 5-wire (option)	2 x 5-wire (option)
Communication					
RS232	✓	✓	✓	✓	✓
CAN	✓	✓	✓	✓	✓
Data acquisition and telemetry					
Data logging (option)	512 kB included	512 kB	512 kB	1 MB	1 or 4 MB
Maximum logging rate	100 Hz	200 Hz	200 Hz	200 Hz	200 Hz
Track mapping	✓	✓	✓	✓	✓
Data analysis using i2 Pro	✗	option	option	option	option
Telemetry	✗	✗	✗	option	option
Remote logging	✗	✗	✗	option	option
Functions and features					
Boost control	✓	✓	✓	✓	✓
Nitrous Injection	✓	✓	✓	✓	✓
Dual stage injection (Hi/Lo injection)	option	✓	✓	✓	✓
Ground speed limiting	✓	✓	✓	✓	✓
Traction and launch control	option	option	option	option	✓
Overrun boost enhancement (anti-lag)	option	option	option	option	✓
Gear change ignition cut (flat shifts)	option	option	option	option	✓
Stepper motor idle control	✓	✓	✓	✓	✓
Continuously variable camshaft control	✗	option	option	option	option
Drive by wire throttle control	✗	option	option	option	option
Servo motor control	✗	✗	✗	option	option
Multi-pulse / Multi-strike	✗	✓	✓	✓	✓
Expander Compatibility	IEX, CDI-8	IEX, CDI-8, E888, E816	IEX, CDI-8, E888, E816	IEX, CDI-8, E888, E816	IEX, CDI-8, E888, E816
Multi-Config	✗	✓	✓	✓	✓
Password Protection of Configs/Logs	✗	✓	✓	✓	✓

Displays

MoTeC D1 Series Color Displays

M D153

Click image to view an animation of screenshots



The D153 display is part of MoTeC's D1 Series. This compact, configurable and high brightness colour display (readable in direct sunlight) is used with MoTeC data loggers. It is designed primarily for mounting on steering wheels, with inputs provided to suit steering wheel mounted switches that allow transmission of switch state on CAN.

Like the MDD it replaces, the D153 is an ideal size for steering wheel mounting and is designed to be controlled and configured by a MoTeC data logger. Numerous inputs are provided for buttons and dials, enabling the unit to activate functions in other CAN-based devices, such as traction control and pitlane speed limiting, with minimal wiring.

MoTeC's initial release provides fixed layouts and selectable channels, allowing users to choose the parameters they wish to monitor in various modes. Full screen configurability will be offered in future and most customers will be able to upgrade their existing unit via a software update

Features

- 90 mm colour LCD display (3.54")
- Compact case for mounting to steering wheels
- High brightness for optimum readability in sunlight
- Receives display messages from MoTeC data loggers
- Sends input data to other devices via CAN
- Provision for up to 14 steering wheel-mounted buttons and dials

Compatibility

The D153 Mini Colour Display is designed to work with MoTeC Data Loggers:

- ACL Advanced Central Logger
- EDL3 Enclosed Advanced Dash Logger
- ESDL3 Enclosed Sport Dash Logger
- ADL3 Advanced Dash Logger
- SDL3 Sport Dash Logger
- CDL3 Club Dash Logger
- Previous Dash Logger models

Item Number	Description
M D153	COLOR MINI DISPLAY

Analog inputs

- Amount: 8 (can be used for switches or potentiometers)
- Measurement range: 0V to 4V
- Maximum operating voltage = 7.0V *
- Maximum protected voltage = 32V
- Input equivalent: 10kΩ to 4.0V

Switch inputs

- Amount: 6
- Threshold High max = 3.5V
- Threshold Low min = 0.8V
- Maximum operating voltage = 32V
- Input equivalent: 10kΩ to 4.0V

Power supply

- Operating voltage = 6.5V to 32V
- Operating current = 380mA (typical) at 14V, full brightness
- Reverse battery protected

Communications

- CAN 1 Mbit/sec

Display

- Type: TFT LCD, anti-reflective
- Resolution: 320 x 240, anti-aliased graphics
- Brightness: controlled via CAN message, 100 steps
- Layouts: selectable fixed layouts

Operating temperature

- Internal: -20°C to 70°C (above 60°C maximum backlight brightness progressively reduced)
- Typical maximum ambient temperature in free air: 50°C

* Above this voltage other inputs may be affected.

MoTeC D1 Series Color Displays

M D175

Click image to view an animation of screenshots



The D175 Display is part of MoTeC's D1 Series. This configurable and high brightness colour display is readable in direct sunlight and includes an integrated LED array; it is used with MoTeC Data Loggers.

Features

- High resolution 125 mm colour LCD display (5" approx)
- 10 integrated full colour LED lights - programmable colour, function and intensity
- High brightness for optimum readability in sunlight
- Receives display messages from MoTeC data loggers
- Sends input data to other devices via CAN
- 8 analogue inputs
- Autosport connector

Compatibility

The D175 Colour Display is designed to work with MoTeC Data Loggers:

- ACL Advanced Central Logger
- EDL3 Enclosed Advanced Dash Logger
- ESDL3 Enclosed Sport Dash Logger
- ADL3 Advanced Dash Logger
- SDL3 Sport Dash Logger
- CDL3 Club Dash Logger
- Previous Dash Logger models

It is envisaged that the D175 will have its own configuration software in future, allowing it to run as a standalone unit.



Item Number	Description
M D175	5" COLOR DISPLAY WITH SLM

Analogue inputs

- Amount: 8 (can be used for switches or potentiometers)
- Measurement range: 0V to 4V
- Maximum operating voltage = 17V *
- Maximum protected voltage = 32V
- Input equivalent: 10kΩ to 4.0V

Power supply

- Operating voltage = 6.5V to 32V
- Operating current = 380mA (typical) at 14V, full brightness
- Reverse battery protected

Communications

- CAN 1 Mbit/sec

Display

- Type: TFT LCD, anti-reflective
- Resolution: 600 x 480, anti-aliased graphics
- Brightness: controlled via CAN message, 100 steps
- Layouts: selectable fixed layouts, user programmable layouts available in future releases.

LED array

- 10 RGB LEDs
- Colour, function and intensity are fully programmable.

Operating temperature

- Internal: -20°C to 70°C (above 60°C maximum backlight brightness progressively reduced)
- Typical maximum ambient temperature in free air: 55°C

Physical

- Weight: 320gms (excluding wiring)
- Anodised aluminium housing

*Above this voltage other inputs may be affected.

Display Loggers

MoTeC C1 Series Color Display Loggers

M C125 USB

Click image to view an animation of screenshots



The C125 is an exciting addition to MoTeC's new range of colour Displays and Display Loggers. The C125 offers display, data logging, auxiliary control and programmable LEDs all in one compact device. The vivid 125mm screen (approx 5") is high resolution, ultra bright and anti-reflective for easy reading in direct sunlight. An array of ten full color LEDs is integrated into the unit for use as shift lights, warning lights or other driver alerts.

Numerous selectable layouts are provided with superb graphics that cater for day and night viewing. Within these layouts users can configure the channels and labels to suit their application. The C125 acquires data from devices such as an ECU and displays data channels, warning alarms, lap times, fuel calculations and much more.

Display

- Type: TFT LCD, anti-reflective
- Resolution: 800 x 480, anti-aliased graphics
- Selectable fixed layouts with channel and label configurability
- 48 user-defined, scrollable message lines with programmable overrides
- 3 programmable 'pages', for example Practice, Warm-Up, Race

Communications

- 2 x Configurable CAN buses with individually programmable CAN bus speeds. One can be used as RS232 Receive
- RS232: 2 x RS232 ports
 - One with Transmit and Receive
 - One with Receive only

Physical

- Dimensions 134.5 x 103.9 x 20.2 mm excluding connector
- Anodised aluminium housing
- Weight 360 g
- 1 x 34 pin waterproof connector

Logging (optional - requires Logging Upgrade)

- 120 MB logging memory
- Logging rates up to 500 samples per second
- Fast Ethernet download
- Includes i2 Standard data analysis software (i2 Pro available as an upgrade)

Inputs (optional - requires I/O Upgrade)

- 6 x analogue voltage inputs
- 2 x analogue temperature inputs
- 2 x digital inputs
- 3 x speed inputs

Outputs (optional - requires I/O Upgrade)

- 4 x low side outputs
- PWM or switched operation

Internal Sensors

- 3-axis G sensor
- Dash temperature sensor
- Sensor supply voltage
- Battery voltage

Expanders

- Compatible with MoTeC E888 and E816 Expanders, providing full functionality.

Item Number	Description
M C125 USB	COLOR DISPLAY LOGGER

C125 USB Upgrades

Data Logging

This upgrade allows for the recording of input data (e.g. from sensors and ECUs) to the C125's internal 120 MB logging memory. It includes use of MoTeC's world class i2 data analysis software. The advanced version, i2 Pro, can be used by purchasing the Pro Analysis Upgrade or a Feature Licence.

Pro Analysis

Provides access to advanced i2 Pro data analysis software with multiple graph overlays, X-Y plots, advanced maths functions, synchronised video (automatic alignment), and flexible layouts to accommodate virtually any user preference.

I/O Upgrade

This upgrade activates additional C125 inputs and outputs. It allows for:

- Wiring of sensors into the C125 using either a custom loom or MoTeC's pre-wired C125 I/O Loom. This professional quality terminated loom adds 6 analogue voltage inputs and 2 analogue temperature inputs.
- Use of 2 digital and 3 speed inputs. These are already pre-wired into the button lead of the C125 Terminated Loom.
- Use of 4 auxiliary outputs; these will require custom wiring.

MoTeC C1 Series Color Display Loggers

M C127 USB

The C127 is a new model in MoTeC's range of Displays and Display Loggers, featuring an impressively generous, high resolution, full colour screen. Stylishly designed and powerful in functionality, the C127 can be upgraded to a logger at any time using a simple password system. Measuring 178 mm (approx. 7 inches), the ultra bright screen is vibrant and anti-reflective, making it easy to view in direct sunlight. Numerous selectable layouts are supplied in various designs, with configurable channels, labels and colour schemes.

The C127 features a total of 16 full colour LEDs integrated into the unit for use as shift lights, warning lights or other driver alerts. The colour, function and intensity of each LED is programmable, allowing users to develop their own unique strategies and sequences.



Item Number	Description
M C127 USB	7" COLOR DISPLAY LOGGER

C127 USB Upgrades

Display Creator

The Display Creator upgrade allows users to design custom graphics and screen layouts for display on the C127 screen, tailoring the look and functionality to a specific application. Designs can incorporate images, logos, icons, colour themes and creative gauge ideas.

The Display Creator software is free to download and experiment, but the upgrade must be enabled in order to send screen configurations to the device.

Data Logging

This upgrade allows for the recording of input data (e.g. from sensors and ECUs) to the C125's internal 120 MB logging memory. It includes use of MoTeC's world class i2 data analysis software. The advanced version, i2 Pro, can be used by purchasing the Pro Analysis Upgrade or a Feature Licence.

Pro Analysis

Provides access to advanced i2 Pro data analysis software with multiple graph overlays, X-Y plots, advanced maths functions, synchronised video (automatic alignment), and flexible layouts to accommodate virtually any user preference.

I/O Upgrade

This upgrade activates additional C125 inputs and outputs. It allows for:

Wiring of sensors into the C125 using either a custom loom or MoTeC's pre-wired C125 I/O Loom. This professional quality terminated loom adds 6 analogue voltage inputs and 2 analogue temperature inputs.

Use of 2 digital and 3 speed inputs. These are already pre-wired into the button lead of the C125 Terminated Loom.

Use of 4 auxiliary outputs; these will require custom wiring.

Display

Type: TFT LCD, anti-reflective
Resolution: 800 x 480, anti-aliased graphics
Selectable fixed layouts with channel and label configurability
48 user-defined, scrollable message lines with programmable overrides
3 programmable 'pages', for example Practice, Warm-Up, Race

Communications

2 x Configurable CAN buses with individually programmable CAN bus speeds. One can be used as RS232 Receive
RS232: 2 x RS232 ports
One with Transmit and Receive
One with Receive only

Physical

Dimensions 196.2 x 122.5 x 24.9 mm excluding connector
Anodised aluminium housing
Weight 615 g
1 x 34 pin waterproof connector

Logging (optional - requires Logging Upgrade)

120 MB logging memory
Logging rates up to 500 samples per second
Fast Ethernet download
Includes i2 Standard data analysis software (i2 Pro available as an upgrade)

Inputs (optional - requires I/O Upgrade)

6 x analogue voltage inputs
2 x analogue temperature inputs
2 x digital inputs
3 x speed inputs

Outputs (optional - requires I/O Upgrade)

4 x low side outputs
PWM or switched operation

Internal Sensors

3-axis G sensor
Dash temperature sensor
Sensor supply voltage
Battery voltage

Expanders

Compatible with MoTeC E888 and E816 Expanders, providing full functionality.

MoTeC C1 Series Color Display Loggers

M C185 USB

With the release of the C185 Display Logger, MoTeC now offers the best of both worlds - a stunning full colour display combined with a powerful, professional level data logger. It comes standard with 250 MB internal logging memory (can be upgraded to 500 MB) and MoTeC's world-renowned i2 data analysis software. A Pro option is available for expert analysis.

The vivid 125mm screen (approx 5") is high resolution, ultra bright and anti-reflective for easy reading in direct sunlight. Numerous selectable layouts are provided with superb graphics that cater for day and night viewing. Within these layouts users can configure the channels and labels to suit their application.

An array of ten full colour LEDs is integrated into the unit for use as shift lights, warning lights or other driver alerts. The colour, function and intensity of each LED is programmable, allowing users to develop their own unique strategies and sequences.



Display

Type: TFT LCD, anti-reflective
 Resolution: 800 x 480, anti-aliased graphics
 Selectable fixed layouts with channel and label configurability
 48 user-defined, scrollable message lines with programmable overrides
 3 programmable 'pages', for example Practice, Warm-Up, Race

Communications

4 x Configurable CAN buses with individually programmable CAN bus speeds.
 One can be used as RS232 Receive
 Two CAN buses support VIM/SVIM Expanders
 2 x dedicated RS232 ports

Physical

Dimensions 134.5 x 103.9 x 20.2 mm excluding connector
 Weight 410 g
 1 x 79 pin Autosport connector

Logging (optional - requires Logging Upgrade)

250 MB logging memory (500 MB optional)
 Logging rates up to 1000 samples per second
 Fast Ethernet download
 Includes i2 Standard data analysis software (i2 Pro available as an upgrade)

Inputs (optional - requires I/O Upgrade)

10 x analogue voltage inputs (20 with I/O upgrade)
 4 x analogue temperature inputs (8 with I/O upgrade)
 4 x digital inputs
 2 x switch inputs
 4 x speed inputs

Outputs (optional - requires I/O Upgrade)

6 x low side outputs
 PWM or switched operation

Internal Sensors

3-axis G sensor
 Dash temperature sensor
 Sensor supply voltage
 Battery voltage

Expanders

Compatible with MoTeC E888 and E816 Expanders, providing full functionality.
 Compatible with MoTeC VIM/SVIM Expanders

Item Number	Description
M C185 USB	COLOR DISPLAY LOGGER

C185 USB Upgrades

Data Logging

Increases the internal logging memory to 500 MB (Standard 250 MB)

Pro Analysis

Provides access to advanced i2 Pro data analysis software with multiple graph overlays, X-Y plots, advanced maths functions, synchronised video (automatic alignment), and flexible layouts to accommodate virtually any user preference.

I/O Upgrade

This upgrade activates additional C185 inputs:
 10 additional analogue voltage inputs
 4 additional analogue temperature inputs
 Use of 4 auxiliary outputs; these will require custom wiring.

Advanced Functions

Enables more complex functionality, including:
 Advanced Maths
 Channel Maths
 16 x 2D Tables (4 as standard)
 16 x 3D Tables (4 as standard)
 50 User Conditions (20 as standard)

T2 Telemetry - Available Soon

Provides access to MoTeC's next generation Telemetry software, more information coming soon.

MoTeC C1 Series Color Display Loggers

M C187 USB

The C187 is MoTeC's latest professional level Display Logger featuring an impressively generous, full colour screen. It comes standard with 250 MB internal logging memory (can be upgraded to 500 MB) and MoTeC's world-renowned i2 data analysis software. A Pro option is available for expert analysis.

The vivid 178mm screen (approx 7") is high resolution, ultra bright and anti-reflective for easy reading in direct sunlight. Choose from numerous selectable layouts and configure the channels, labels and colours to suit. Or, opt for the new Display Creator upgrade and treat your screen as a blank canvas - design your own unique graphics, incorporate images, logos and custom icons. Create multiple pages to suit different scenarios, optimising the screen space for your application.

An array of 16 full colour LEDs is integrated into the unit for use as shift lights, warning lights or other driver alerts. The colour, function and intensity of each LED is programmable, allowing users to develop their own unique strategies and sequences.



Item Number	Description
M C187 USB	7" COLOR DISPLAY LOGGER

C187 USB Upgrades

Data Logging

Increases the internal logging memory to 500 MB (Standard 250 MB)

Pro Analysis

Provides access to advanced i2 Pro data analysis software with multiple graph overlays, X-Y plots, advanced maths functions, synchronised video (automatic alignment), and flexible layouts to accommodate virtually any user preference.

I/O Upgrade

This upgrade activates additional C185 inputs:
10 additional analogue voltage inputs
4 additional analogue temperature inputs

Advanced Functions

Enables more complex functionality, including:

- Advanced Maths
- Channel Maths
- 16 x 2D Tables (4 as standard)
- 16 x 3D Tables (4 as standard)
- 50 User Conditions (20 as standard)

T2 Telemetry - Available Soon

Provides access to MoTeC's next generation Telemetry software

Display

Type: TFT LCD, anti-reflective
Resolution: 800 x 480, anti-aliased graphics
Selectable fixed layouts with channel and label configurability
48 user-defined, scrollable message lines with programmable overrides
3 programmable 'pages', for example Practice, Warm-Up, Race

Communications

4 x Configurable CAN buses with individually programmable CAN bus speeds.
One can be used as RS232 Receive
Two CAN buses support VIM/SVIM Expanders
2 x dedicated RS232 ports

Physical

Dimensions 196.2 x 122.5 x 24.9 mm excluding connector
Weight 670 g
1 x 79 pin Autosport connector

Logging (optional - requires Logging Upgrade)

250 MB logging memory (500 MB optional)
Logging rates up to 1000 samples per second
Fast Ethernet download
Includes i2 Standard data analysis software (i2 Pro available as an upgrade)

Inputs (optional - requires I/O Upgrade)

10 x analogue voltage inputs (20 with I/O upgrade)
4 x analogue temperature inputs (8 with I/O upgrade)
4 x digital inputs
2 x switch inputs
4 x speed inputs

Outputs (optional - requires I/O Upgrade)

6 x low side outputs
PWM or switched operation

Internal Sensors

3-axis G sensor
Dash temperature sensor
Sensor supply voltage
Battery voltage

Expanders

Compatible with MoTeC E888 and E816 Expanders, providing full functionality.
Compatible with MoTeC VIM/SVIM Expanders

M1212 USB

The C1212 is a new model in MoTeC's range of Displays and Display Loggers, featuring an impressively generous, high resolution, full colour screen. Stylishly designed with powerful functionality, the C1212 provides all the benefits of a sophisticated display plus data logging and auxiliary control in one streamlined device.

This model also includes a composite video input as standard (e.g. for a rear vision camera), and USB Logging to a removable storage device as an optional upgrade.

Measuring 311mm (approx. 12 inches), the ultra bright C1212 screen is vibrant and anti-reflective, making it easy to view in direct sunlight. Numerous selectable layouts are supplied with configurable channels, labels and colour schemes. Or, for the flexibility to treat your screen as a blank canvas and design your own layout with unique graphics, sponsor logos, custom icons and gauges, opt for the Display Creator upgrade.



M1212 USB Upgrades

120 MB Logging

NEW VERSION Logging Level 1 upgrade allows for the recording of input data (e.g. from sensors and ECUs) to the C1212's internal 120 MB logging memory. It includes use of MoTeC's world class i2 data analysis software. The advanced version, i2 Pro, can be used by purchasing the Pro Analysis Upgrade or a Feature Licence.

USB Logging ‡

Logging Level 2 upgrade further enhances Logging Level 1 upgrade to include USB logging. It includes the required "Custom USB Logging" cable.

I/O Upgrade

This upgrade activates additional C1212 inputs and outputs. It allows for:

- Wiring of sensors into the C1212 using either a custom loom or MoTeC's pre-wired C1212 I/O Loom. This professional quality terminated loom adds 6 analogue voltage inputs and 2 analogue temperature inputs.
- Use of 2 digital and 3 speed inputs. These are already rewired into the button lead of the C1212 Terminated Loom.
- Use of 4 auxiliary outputs; these will require custom wiring.

Display Creator

The Display Creator upgrade allows users to design custom graphics and screen layouts for display on the C1212 screen, tailoring the look and functionality to a specific application. Designs can incorporate images, logos, icons, colour themes and creative gauge ideas.

The Display Creator software is free to download and experiment, but the upgrade must be enabled in order to send screen configurations to the device.

Pro Analysis

Provides access to advanced i2 Pro data analysis software with multiple graph overlays, X-Y plots, advanced maths functions, synchronised video (automatic alignment), and flexible layouts to accommodate virtually any user preference.

T2 Telemetry

Provides access to MoTeC's next generation T2 Telemetry software.

Display

For full customisation of the display layout and graphics add the Display Creator option.

Screen: Colour TFT LCD, anti-reflective

Resolution: 1280 x 480, anti-aliased graphics

Selectable fixed layouts with channel and label configurability

48 user-defined, scrollable message lines with programmable overrides

3 programmable 'pages', for example Practice, Warm-Up, Race

Communications

2 x Configurable CAN buses with individually programmable CAN bus speeds

One can be used as RS232 Receive

RS232: 2 x RS232 ports

One with Transmit and Receive

One with Receive only

Physical

Dimensions 340.8 x 147.6 x 34 mm excluding connector

Weight 1.690 kg

1 x 34 pin waterproof connector

1 x mini USB port

Logging (optional - requires Logging Upgrade)

Level 1: 120 MB logging memory

Level 2: USB Logging to a removable storage device (flash drive)

32 GB USB storage devices available

Logging rates up to 500 samples per second

Fast Ethernet download

Includes i2 Standard data analysis software (i2 Pro available as an upgrade)

Inputs

2 x Digital inputs

3 x Speed inputs

1 x Composite Video Input for the connection of a PAL or NTSC camera

Inputs (optional - requires I/O Upgrade)

6 x Analogue voltage inputs

2 x Analogue temperature inputs

Outputs (optional - requires I/O Upgrade)

4 x low side outputs

PWM or switched operation

Internal Sensors

3-axis G sensor

Dash temperature sensor

Sensor supply voltage

Battery voltage

Expanders

Compatible with MoTeC E888 and E816 Expanders, providing full functionality.

‡ Requires 120 MB Logging

M1812 USB

The C1812 is MoTeC's latest professional level Display Logger featuring an impressively generous, full colour screen. It comes standard with 250 MB internal logging memory and MoTeC's world-renowned i2 data analysis software. A Pro option is available for expert analysis.

C1812s now offer the convenience and flexibility of USB Logging, an optional upgrade that can be enabled in the field at any time. This upgrade also increases the internal memory to 500 MB. In addition, recently built models provide three composite video inputs for a live camera feed on the display screen.

The vivid 311mm screen (approx 12") is high resolution, ultra bright and anti-reflective for easy reading in direct sunlight. Choose from numerous selectable layouts and configure the channels, labels and colours to suit. Or, opt for the Display Creator upgrade and treat your screen as a blank canvas with unique graphics, images, logos and custom icons. Create multiple pages to suit different scenarios, optimising the screen space for your application.



Display

For full customisation of the display layout and graphics add the Display Creator option.

Screen: Colour TFT LCD, anti-reflective

Resolution: 1280 x 480, anti-aliased graphics

Selectable fixed layouts with channel and label configurability

48 user-defined, scrollable message lines with programmable overrides

3 programmable 'pages', for example Practice, Warm-Up, Race

Logging

250 MB internal logging memory

Optional USB Logging to a removable storage device (flash drive)

includes upgrade to 500 MB internal memory

Logging rates up to 1000 samples per second

Fast Ethernet download

Includes i2 Standard data analysis software (i2 Pro available as an upgrade)

Communications

4 x configurable CAN buses with individually programmable CAN bus speeds

One can be used as RS232 Receive

Two CAN buses support VIM/SVIM Expanders

2 x dedicated RS232 ports

Physical

Dimensions 340.8 x 147.6 x 34 mm excluding connector, connector bosses and studs

Weight 1.712kg

1 x 79 pin Autosport connector

1 x mini USB port

Inputs

10 x analogue voltage inputs (20 with I/O Upgrade)

4 x analogue temperature inputs (8 with I/O upgrade)

4 x digital inputs

2 x switch inputs

4 x speed inputs

3 x Composite Video Inputs for the connection of PAL or NTSC cameras

Outputs

6 x low side outputs

PWM or switched operation

Internal Sensors

3-axis G sensor

Dash temperature sensor

Sensor supply voltage

Battery voltage

Expanders

Compatible with MoTeC E888 and E816 Expanders, providing full functionality.

M1812 USB Upgrades

500Mb + USB Logging

Logging Level 2 upgrade increases the C1812's internal logging memory to 500 MB and enables the use of USB logging. It includes the required "Custom USB Logging" cable.

It also comes with use of MoTeC's world class i2 data analysis software. The advanced version, i2 Pro, can be used by purchasing the Pro Analysis Upgrade or a Feature Licence.

44 I/O

This upgrade activates additional C1812 inputs and outputs. It allows for:

- 10 additional analogue voltage inputs
- 4 additional analogue temperature inputs

Display Creator

The Display Creator upgrade allows users to design custom graphics and screen layouts for display on the C1812 screen, tailoring the look and functionality to a specific application. Designs can incorporate images, logos, icons, colour themes and creative gauge ideas.

The Display Creator software is free to download and experiment, but the upgrade must be enabled in order to send screen configurations to the device.

Pro Analysis

Provides access to advanced i2 Pro data analysis software with multiple graph overlays, X-Y plots, advanced maths functions, synchronised video (automatic alignment), and flexible layouts to accommodate virtually any user preference.

T2 Telemetry

Provides access to MoTeC's next generation T2 Telemetry software.

Advanced Functions

Enables more complex functionality, including:

- Advanced Maths
- Channel Maths
- 16 x 2D Tables (4 as standard)
- 16 x 3D Tables (4 as standard)
- 50 User Conditions (20 as standard)

Club Dash Logger 3 (CDL3)

The Club Dash Logger (CDL3) comes standard as a combined backlit display and powerful control device in one lightweight unit. With the addition of the Data Logging upgrade it becomes a fully programmable data logger with 8MB memory. It offers the same construction and advanced technology as the top of the line ADL3, with a package of features tailored to entry level motorsport requirements. The screen layout is fully configurable to display a multitude of data channels, warning alarms, lap times, fuel calculations, minimum corner speeds, maximum straight speeds and more. The CDL3 performs calculations, acquiring data from other devices such as an ECU.

Features

- All-in-one display, logger and controller
- Suitable for bikes, cars, marine and industrial applications
- Compact, durable and reliable unit
- Supports Wideband Lambda from MoTeC PLMs or LTCs
- Easily integrates with MoTeC CAN-based expanders, GPS, shift lights and ECUs



Item Number	Description
M CDL3	CLUB DISPLAY LOGGER

Inputs

- 4 x Analogue voltage high resolution inputs
- 2 x Analogue temperature inputs
- 2 x Digital inputs
- 3 x Speed inputs with voltage measuring capability
- Compatible with E888 expander (8 Thermocouples only)

Outputs

- 4 x PWM, switched or digital outputs Logging
- 8 MB logging memory
- Logging rates up to 500 samples per second
- Fast Ethernet download Additional Information

Compatibility

- MoTeC ECUs: M4, M48, M8, M84, M400, M600, M800 and M880
- MoTeC Accessories: MDD, E888, SLM, PLM, LTC, BR2, PDM, GPS, VCS etc.
- Many non-MoTeC devices

CDL3 Upgrades

Data Logging

Allows recording of input data (e.g from sensors and ECUs) to the CDL3's 8 MB internal logging memory and includes use of MoTeC's i2 Standard data analysis software. i2 Pro can be used by purchasing a Feature Licence.

12 I/O Upgrade

This upgrade activates additional CDL3 inputs and outputs. It allows for:
 Wiring of 6 sensors into the CDL3 using either a custom loom or MoTeC's pre-wired CDL3 I/O Loom. This professional quality terminated loom adds 4 analogue voltage inputs and 2 analogue temperature inputs.
 Use of 2 digital and 3 speed inputs. These are already pre-wired into the button lead of the CDL3 Terminated Loom.
 Use of 4 auxiliary outputs; these will require custom wiring.

Accessory Kit

- M CDL3 ACC KIT
- CDL3 ACCESSORY KIT



Club Shift Light Module



CDL3 Wiring Loom



2 Button Loom



10Hz GPS

Loggers

MoTeC L1 Series Enclosed Loggers

M L120

The L120 Enclosed Logger is a multipurpose device that can be used in a range of applications depending upon which options are enabled.

USES

D Series Display Controller

Any L120 can be used as a controller for any MoTeC D series display. The L120 can forward all of the channels required for the driver to the D153 or D175, including lap timing, CAN and RS232 channels and much more.

Fully Featured Logger (with optional upgrades 29601 and 29619)

With the I/O and logging upgrades, the L120 can log any CAN and RS232 bus, as well as inputs wired directly to the box. This powerful logger can be placed anywhere in the vehicle, ensuring that the weight can be kept low and wiring to a minimum.

CAN and RS232 Logger (with optional upgrade 29619)

With the logging upgrade only, the L120 can be placed anywhere in the vehicle, and used to log any channels from both of the L120 CAN buses, as well as the RS232 bus. With only Power, CAN and RS232 connections, this is a simple to use enclosed logger.

T2 Telemetry Box (with optional upgrade 29621)

Using the L120 as a T2 box (optional upgrade) incorporates MoTeC's T2 telemetry system when you don't have a MoTeC colour display in the vehicle. The L120 with the T2 upgrade can receive messages from most other CAN units (such as non MoTeC ECUs and data loggers), convert it to a T2 data stream and transmit it out to the Radio for the pit side T2 system.

Can Bus Bridge

When the L120 is used without any upgrades, it can be used as a device that can take messages from one bus and pass it onto another. This is very useful where a vehicle has information that needs sharing, but the two CAN buses are incompatible, such as different bus speeds.

FEATURES

Suitable for bikes, cars, marine and industrial applications
Supports Wideband Lambda from MoTeC PLMs or LTCs
Easily integrates with MoTeC CAN based products such as ECUs and expanders. Full I/O expansion available with use of E888, E816 expanders.

- GPS Lap Timing
- Supports T2 Telemetry

Item Number	Description
M L120	ENCLOSED LOGGER

COMPATIBILITY

MoTeC ECUs: M4*, M48*, M8*, M84, M400, M600, M800, M880, M1
MoTeC Accessories: E816, E888, SLM, PLM, LTC, BR2, PDM, GPS, VCS etc.

Many non-MoTeC devices

* For some ECUs, an additional cable/adaptor may be required in conjunction with the RS232 adaptor.



Logging - optional (requires logging upgrade)

- 120 MB logging memory
- Logging rates up to 500 samples per second
- Fast Ethernet download
- Includes i2 Standard data analysis software (Pro Analysis upgrade available)
- Inputs
 - 2 Digital and 3 Speed inputs
 - Inputs -optional (requires I/O upgrade)
 - 6 analogue voltage inputs:
 - 4 x 0 to 5.46 V, 1.33 mV resolution
 - 2 x 0 to 15.0 V, 3.66 mV resolution
 - 2 analogue temperature inputs
 - 0 to 15 V, 3.66 mV resolution
- Outputs - optional (requires I/O upgrade)
 - 4 low side outputs PWM or switched operation
 - 0.5 Amp max, current limited and thermal overload protected

Expanders

- Compatible with E816 and E888 expanders (providing full functional use)

Internal Sensors

- 3-axis accelerometer, detection range: +/-5G
- Temperature sensor
- Sensor supply voltage
- Battery voltage

Communications

- 2 configurable CAN buses, with individually programmable CAN bus speeds. One can be used as RS232 Receive.
- 2 RS232 ports, one with transmit and receive, one with receive only

Power supply

- Operating voltage: 6 to 32 V DC
- Operating current: 0.4 A typical at 14 V (excluding sensor currents)
- Reverse battery protection
- Battery transient protection
- Sensor supply currents
 - 5 V sensor supply: 0.25 A maximum
 - 8 V sensor supply: 0.25 A maximum

Operating temperature

- Internal: -20 °C to 80 °C
- Typical ambient temperature range in free air: -20 °C to 65 °C

Physical

- Size: 134.5 x 103.9 x 20.2 mm excluding connector and tab
- Weight 289 g
- 1 x 34 pin waterproof connector

MoTeC L1 Series Enclosed Loggers

M L120 USB

The L120 (USB) Enclosed Logger is a multipurpose device that can be used in a range of applications depending upon which options are enabled.

USES

D Series Display Controller

Any L120 (USB) can be used as a controller for any MoTeC D series display. The L120 (USB) can forward all of the channels required for the driver to the D153 or D175, including lap timing, CAN and RS232 channels and much more.

Fully Featured Logger (with optional upgrades 29601)

With the I/O and logging upgrades, the L120 (USB) can log any CAN and RS232 bus, as well as inputs wired directly to the box. This powerful logger can be placed anywhere in the vehicle, ensuring that the weight can be kept low and wiring to a minimum.

CAN and RS232 Logger

The L120 (USB) can be placed anywhere in the vehicle, and used to log any channels from both of the L120 (USB) CAN busses, as well as the RS232 bus. With only Power, CAN and RS232 connections, this is a simple to use enclosed logger.

T2 Telemetry Box

Using the L120 (USB) as a T2 box (optional upgrade) incorporates MoTeC's T2 telemetry system when you don't have a MoTeC colour display in the vehicle. The L120 (USB) with the T2 upgrade can receive messages from most other CAN units (such as non MoTeC ECUs and data loggers), convert it to a T2 data stream and transmit it out to the Radio for the pit side T2 system.

Can Bus Bridge

When the L120 (USB) is used without any upgrades, it can be used as a device that can take messages from one bus and pass it onto another. This is very useful where a vehicle has information that needs sharing, but the two CAN busses are incompatible, such as different bus speeds.

FEATURES

Suitable for bikes, cars, marine and industrial applications
Supports Wideband Lambda from MoTeC PLMs or LTCs
Easily integrates with MoTeC CAN based products such as ECUs and expanders. Full I/O expansion available with use of E888, E816 expanders.
GPS Lap Timing
Supports T2 Telemetry

Item Number	Description
M L120 USB	ENCLOSED LOGGER

COMPATIBILITY

MoTeC ECUs: M4*, M48*, M8*, M84, M400, M600, M800, M880, M1

MoTeC Accessories: E816, E888, SLM, PLM, LTC, BR2, PDM, GPS, VCS etc.

Many non-MoTeC devices

* For some ECUs, an additional cable/adaptor may be required in conjunction with the RS232 adaptor.



Logging

120 MB logging memory + USB logging
Logging rates up to 500 samples per second
Fast Ethernet download
Includes i2 Standard data analysis software (Pro Analysis upgrade available)

Inputs

2 Digital and 3 Speed inputs
Inputs -optional (requires I/O upgrade)
6 analogue voltage inputs:
4 x 0 to 5.46 V, 1.33 mV resolution
2 x 0 to 15.0 V, 3.66 mV resolution
2 analogue temperature inputs
0 to 15 V, 3.66 mV resolution

Outputs - optional (requires I/O upgrade)

4 low side outputs PWM or switched operation
0.5 Amp max, current limited and thermal overload protected

Expanders

Compatible with E816 and E888 expanders (providing full functional use)

Internal Sensors

3-axis accelerometer, detection range: +/-5G
Temperature sensor
Sensor supply voltage
Battery voltage

Communications

2 configurable CAN buses, with individually programmable CAN bus speeds.
One can be used as RS232 Receive.
2 RS232 ports, one with transmit and receive, one with receive only

Power supply

Operating voltage: 6 to 32 V DC
Operating current: 0.4 A typical at 14 V (excluding sensor currents)
Reverse battery protection
Battery transient protection
Sensor supply currents
5 V sensor supply: 0.25 A maximum
8 V sensor supply: 0.25 A maximum

Operating temperature

Internal: -20 °C to 80 °C
Typical ambient temperature range in free air: -20 °C to 65 °C

Physical

Size: 134.5 x 103.9 x 20.2 mm excluding connector and tab
Weight 289 g
1 x 34 pin waterproof connector

MoTeC L1 Series Enclosed Loggers

M L180



The L180 Enclosed Logger is a powerful control device and fully programmable data logger with 250 MB memory. USB logging is optional and increases the internal memory to 500 MB. It acquires data from devices such as an ECU can be used in a range of applications.

Features

Suitable for bikes, cars, marine and industrial applications
Can be used as a controller for any MoTeC D series display, forwarding all required channels to the display, including lap timing, CAN and RS232 channels and much more.

Logging

250 MB logging memory (500 MB + USB optional)
Logging rates up to 1000 samples per second
Fast Ethernet download
Includes i2 Standard data analysis software (Pro Analysis upgrade available)

Inputs

10 (20 with I/O upgrade*) analogue voltage inputs:
4 (8*) x 0 to 5.46 V, 1.33 mV resolution 6 (12*) x 0 to 15.0 V, 3.66 mV resolution
2 x 0 to 15.0 V, 3.66 mV resolution
4 (8 with I/O upgrade) analogue temperature inputs
0 to 15 V, 3.66 mV resolution
4 Digital inputs
2 Switch inputs
4 Speed inputs

Outputs

6 low side outputs PWM or switched operation
1.0 Amp max, current limited and thermal overload protected

Expanders

Compatible with E816 and E888 expanders (providing full functional use), VIM & SVIM

Internal Sensors

3-axis accelerometer, detection range: +/-5G
Temperature sensor
Sensor supply voltage
Battery voltage

Communications

4 configurable CAN buses, with individually programmable CAN bus speeds. One can be used as RS232 Receive. Only 2 of the CAN buses support VIM/SVIM Expanders.
2 dedicated RS232 ports

Power supply

Operating voltage: 6 to 32 V DC
Operating current: 0.4 A typical at 14 V (excluding sensor currents)
Reverse battery protection
Battery transient protection
Sensor supply currents
5 V sensor supply: 0.25 A maximum
8 V sensor supply: 0.25 A maximum

Operating temperature

Internal: -20 °C to 80 °C
Typical ambient temperature range in free air: -20 °C to 65 °C

Physical

Size: 134.5 x 103.9 x 20.2 mm excluding connector
Weight 343 g
1 x 79 pin Autosport connector

Can be placed anywhere in the vehicle and log any CAN and RS232 bus, as well as inputs wired directly to the box.

The T2 Telemetry optional upgrade adds the T2 Telemetry system into the vehicle. The L180 with the T2 upgrade can receive messages from most other CAN units (such as non MoTeC ECUs and data loggers), convert it to a T2 data stream and transmit it out to the radio for the pit side T2 system.

Supports Wideband Lambda from MoTeC PLMs or LTCs
Easily integrates with MoTeC CAN based products such as ECUs and expanders. Full I/O expansion available with use of E888, E816, VIM and SVIM expanders.

GPS Lap Timing

Tell Tales

Diagnostic Logging

Preserved Channels

Running Min/Max, Timers, PID Control, Engine Log.

Accessories

62206 – C185 LOOM

Optional Upgrades

29715 – L180 500MB + USB LOGGING

29702 – L180 44 I/O

10 extra analogue voltage inputs (AV11 to AV20, see pinout)

4 extra analogue temperature inputs (AT5 to AT8, see pinout)

29721 – L180 PRO ANALYSIS

29724 – L180 T2 TELEMETRY (2nd generation Telemetry)

29706 – L180 ADVANCED FUNCTIONS

Advanced Functions provides:

Advanced Maths

Channel Maths

16 x 2D Tables (instead of 4)

16 x 3D Tables (instead of 4)

50 User Conditions (instead of 20)

Item Number	Description
M L180	ENCLOSED LOGGER

Advanced Central Logger (ACL)

The Advanced Central Logger (ACL) is a highly configurable data acquisition and communications tool that is well suited to professional teams who place serious demands on their data equipment. With 1 GB of logging memory it forms the heart of MoTeC's Central Logging System, which also includes multiple VIMs Versatile Input Modules for high resolution sensor inputs.

The ACL performs data logging, data communication and sophisticated calculations, acquiring data from other MoTeC devices such as an ECU, Dash Logger and up to eight VIMs, which enable it to log more than 200 inputs. It provides all the advanced features of the ADL3, including warning alarms, fuel prediction, engine logs, timers, tables, user conditions and telemetry. For maximum flexibility the ACL connects to any MoTeC display.

MoTeC's Central Logging System follows a modular concept, employing separate dedicated devices for inputs, and logging, thereby allowing customers to tailor a solution to their application. The system is simple to set up as most connected devices are configured and upgraded from one software application.

The ACL comes as standard with Pro Analysis enabled, allowing unrestricted use of MoTeC's professional level i2 Pro data analysis software.



Item Number	Description
M ACL	ADVANCED CENTRAL LOGGER

ACL Upgrades

Several options are available as upgrades to customise and grow your system. These additional features are activated through a simple password system, at any time when you need it.

For the ACL data logger the following upgrades are available:

Telemetry

Enables transmission of live data from the vehicle to the pit where it can be viewed in real time using the MoTeC Telemetry Monitor software. Requires radio modems or other means of transmission.

Remote Logging

Enables converting telemetry data into a log file to use with i2 analysis software. Requires the Telemetry upgrade.

Display

ACL data can be displayed via a MoTeC display such as SDL or MDD

Communications

2 x CAN with individually programmable CAN bus speeds
1 x RS232
1 x RS485 which can also read data from RS232 devices

Physical

Dimensions 154 x 128 x 28 mm (excluding connector)
Weight 460 grams
1 x 5 pin and 1 x 22 pin Autosport connector

Logging

1 GB logging memory
Very fast download via Ethernet
Very fast logging rates up to 5000 samples/second
Combined logging rates greater than 20 MB/minute

Inputs

Data is read into the ACL via one or more input devices. These can include VIMs, E888, E816, SDL, PLM, ECU and GPS

Outputs

Outputs can be controlled by the ACL when connected to an output device such as an E888, E816 or SDL

Data Logger Chart

KEY: *table tick - standard available*
table cross - not available
option - requires optional upgrade

Data Acquisition Comparison Table					
	CDL3	L120	C125/127/1212 L120(USB)	C185/187/1812 L180	ACL
Display					
Type	<i>Reflective Mono LCD</i>	<i>No display</i>	<i>Ultra Bright Color No display on L120(USB)</i>	<i>Ultra Bright Color No display on L180</i>	<i>No display</i>
Backlight	<i>table tick</i>	<i>No display</i>	<i>table tick table cross on L120(USB)</i>	<i>table tick table cross on L180</i>	<i>No display</i>
Display modes	3	<i>No display</i>	3 <i>More with Display Creator table cross on L120(USB)</i>	3 <i>More with Display Creator table cross on L180</i>	<i>No display</i>
Supports Display Creator	<i>table cross</i>	<i>table cross</i>	<i>Optional table cross on L120(USB)</i>	<i>Optional table cross on L180</i>	<i>table cross</i>
Data acquisition and telemetry					
Data Logging memory	8 MB	120 MB <i>(Optional)</i>	L1 120 MB <i>(Optional)</i> L2 USB <i>(Optional)</i> <i>table tick L2 included on L120(USB)</i>	250 MB 500 MB + USB <i>(Optional)</i>	1 GB
Logging rate	1 - 500Hz	1 - 500Hz	1 - 500Hz	1 - 1000Hz	1 - 5000Hz
Analysis using i2 Standard	<i>Optional</i>	<i>Optional</i>	<i>Optional</i>	<i>Optional</i>	<i>table tick</i>
Analysis using i2 Pro	<i>Optional</i>	<i>Optional</i>	<i>Optional</i>	<i>Optional</i>	<i>table tick</i>
T2 Telemetry	<i>table cross</i>	<i>Optional</i>	<i>Optional</i>	<i>Optional</i>	<i>Optional</i>
Inputs					
Analogue voltage	4	6 <i>(Optional)</i>	6 <i>(Optional)</i>	10 20 <i>(Optional)</i>	<i>via VIM, SDL, E888, E816</i>
Analogue temperature	2	2 <i>(Optional)</i>	2 <i>(Optional)</i>	4 8 <i>(Optional)</i>	<i>via SDL</i>
Digital	2	2 <i>(Optional)</i>	2 <i>(Optional)</i>	4	<i>via VIM, SDL, E888, E816</i>
Speed	3	3 <i>(Optional)</i>	3 <i>(Optional)</i>	4	<i>via VIM, SDL</i>
Switch	<i>table cross</i>	<i>table cross</i>	<i>table cross</i>	2	<i>via SDL, E888, E816</i>
Wideband Lambda	<i>via PLM or LTC</i>	<i>via PLM or LTC</i>	<i>via PLM or LTC</i>	<i>via PLM or LTC</i>	<i>via PLM or LTC</i>
Expansion units	<i>E888 (8 thermocouples only)</i>	<i>E888/816 (full functionality)</i>	<i>E888/816 (full functionality)</i>	<i>E888/E816 SVIM/VIM</i>	<i>up to 8 x VIM and 2 x E888/816</i>
Outputs					
Digital, Switched, PWM	4	4	4	6	<i>via E888, E816</i>
Expansion units	<i>table cross</i>	1 or 2 x <i>E888/816</i>	1 or 2 x <i>E888/816</i>	1 or 2 x <i>E888/816</i> 1 or 2 x <i>VIM/SVIM</i>	1 or 2 x <i>E888/816</i>
Communications					
CAN	2	2	2	4	2
RS232	<i>table tick</i>				
RS422, RS485	<i>table cross</i>	<i>table cross</i>	<i>table cross</i>	<i>table cross</i>	<i>table tick</i>
PC Connection					
Ethernet	<i>table tick</i>	<i>table tick</i>	<i>table tick</i>	<i>table tick</i>	<i>table tick</i>
	CDL3	L120	C125/127/1212 L120(USB)	C185/187/1812 L180	ACL

Lights

Billet Shift / Warning Indicator

The Shift Light Module (SLM) may be used for shift lights, warning lights or other indicators as programmed by the user.

It provides eight multicolour LED indicator lights in a compact array. The colour, intensity and purpose of each LED can be controlled independently, providing enormous flexibility and scope for customisation.

A set of patterns can be defined with various colour combinations and flashing modes, indicating for example: stop immediately, continue with caution, pit lane speed limiter active and of course, up-shift and down-shift. The LEDs can be programmed in a priority order so that, for example, a warning light can override a shift light.

The SLM is configured and controlled using a MoTeC ECU, display or data logger. Compatible MoTeC devices have special programming functions for the SLM. The module is connected via CAN eliminating the need to use auxiliary outputs.



Compatible with

- SDL3
- ADL3
- ACL (software version V1.10F2 and later)
- M400, M600, M800, M880 (software version V3.41G and later), M84

Item Number	Description
M SLM	SHIFT LIGHT MODULE
M SLM USA	SHIFT LIGHT MODULE W/ ANGLED BASE

LEDs

- 8 full colour (RGB) LEDs

Communications

- CAN

Physical

- Case size 81.2 x 19.0 x 16.0 mm
- 1 x 4 pin Deutsch DTM connector, flying lead



Video

MoTeC V2 Video Kit

MoTeC's V2 Video Kit is a robust High Definition video recording system designed specifically for motorsport. The V2 unit itself is compact and lightweight, housing the high quality camera and recording components, while the kit provides the mounting hardware and accessories to make installation quick and easy.

Features:

- Full HD: Genuine High Definition with 1080p @ 30 frames per second
- Automatic Start/Stop, eliminating the possibility of drivers forgetting to turn it on
- 12 V power direct from the vehicle - no batteries to recharge
- Live gauges automatically recorded on the video - no post processing required
- Compact and lightweight all-in-one camera and recording unit - only 100gms (exc. mounts)
- Flexible roll cage mounting system - compatible with some GoPro mounting hardware
- Over 14 hours recording at 1080p
- Records to a removable micro SD card up to 32GB - the kit includes an SD card adaptor
- Video can be played directly from the card
- Automatic CAN Synchronisation with data in i2
- Built in microphone
- Dedicated V2 Manager software for configuring the video, audio, CAN and gauges



Recording FormatS - WITH OR WITHOUT LIVE GAUGES Recorder:

- 1920 x 1080 @ 30 fps (default)
- 1920 x 1080 @ 25 fps
- 1280 x 720 @ 60 fps
- 1280 x 720 @ 50 fps
- 1280 x 720 @ 30 fps
- 1280 x 720 @ 25 fps

Compatibility

- MoTeC Data Loggers: C125, C127, C1212, C185, C187, C1812, CDL3, SDL, SDL3, ADL, ADL2, ADL3 and ACL
- MoTeC M1 Series ECUs (depending on Package)
- MoTeC "Hundred Series" and M84 ECUs
- Other manufacturers' devices may be compatible with the V2 over CAN, however data sync in i2 won't work.
- The V2 can be used standalone but no data will be overlaid onto video footage
- Works with i2 Pro and i2 Standard

V2 VIDEO Kit Contents

- V2 Video Recording Unit (includes built in camera)
- 32 GB Micro SD Card with SD card adaptor
- V2 Power/CAN Loom
- V2 Mounting Kit
- V2 Camera Mount

Item Number	Description
18210	HD VIDEO CAPTURE SYSTEM

Note: The V2 recording unit is supplied with a ferrite core (not shown) that must be fitted to the V2 loom before use.

Video Sync Module (VSM)

MoTeC's Video Capture System (VCS) is an integrated in-car camera system, designed and built for race cars and harsh environments. The VCS records video and audio using the MPEG-2 video compression format at broadcast quality. It includes a built in real-time graphics processor that allows sensor data to be overlaid onto the video in real-time without the need for additional hardware. The CAN interface enables communication with other devices, for example to set Auto Start/Stop Recording conditions. The Video Capture System is supplied as a kit with either a 4 GB or a 16 GB high performance flash card.

The kit includes:

- VCS Pro Recorder
- Camera
- Microphone
- Mini-USB B to USB A Male Cable
- VCS Adapter Loom
- VCS Power / CAN Loom
- Roll Cage Mounting Bracket
- VCS Mounting Plate



On Screen Display

The video may have the following data overlaid if the required sensors are installed in the vehicle:

- Throttle Position: displayed as a vertical green bar graph scaled between 0% and 100%
- Ground Speed: displayed as a gauge from 0 to 300 kph with overlaid numeric value
- RPM: displayed as a gauge from 0 to 9000 rpm with overlaid text value
- G force: displayed as a G circle from 0 to 2G with an indicator point and an overlaid text value for lateral and longitudinal G
- Brake Switch: displayed as a vertical red bar graph
- Gear: displayed numeric in the centre
- Lap number, Lap time, Last lap time: displayed numeric
- Steering: displayed as a steering wheel

Item Number	Description
M VSM	VIDEO SYNC MODULE

Expansion Boxes

Synchronous Versatile Input Module (SVIM)

The Synchronous Versatile Input Module (SVIM) is a compact expander that works in conjunction with an ACL or ADL3 Data Logger to facilitate the synchronised logging of high speed, high resolution inputs.

The SVIM acquires data of the highest integrity for use in advanced chassis and suspension analysis. It samples 18 inputs at the same instant in time using 18 separate converters with 5th order anti-aliasing filters.

Multiple SVIMs are synchronised so that every SVIM in the vehicle samples its high resolution AV inputs at the same instant in time. This is important when looking at the relationships of signals collected from different sensors around the vehicle and is useful for test rigs and real time simulations.

SVIMs are versatile in nature and can be located close to sensors, reducing the weight and complexity of wiring. When used in multiples, up to 200 sensor inputs are available. The SVIM supports many different types of sensors, including unamplified thermocouples and strain gauges.

The SVIM is configured and controlled using the Data Logger Manager software, that has special programming functions for the SVIM. This will also automatically update the firmware version in the SVIM if necessary. The Data Logger communicates to the SVIM via the CAN bus.



Compatible with

- ACL (up to eight SVIMs)
- ADL3 (up to two SVIMs)

Inputs

- 6 x Fast analogue voltage inputs
Update rate 5000 Hz (1000 Hz when used with ADL3) , resolution 12 bit
Used to measure the signals from sensors with variable voltage outputs, such as potentiometers, 3-wire pressure sensors, thermocouple amplifiers, accelerometers
- 10 x High resolution analogue voltage inputs
Update rate 1000 Hz, resolution 15 bit
Used to measure the signals from sensors with variable voltage outputs, such as potentiometers, 3-wire pressure sensors, thermocouple amplifiers, accelerometers
- 8 x Differential analogue voltage inputs
Update rate 1000 Hz, resolution 15 bit +sign
Programmable amplifier gain range of 1 to 64, used for strain gauges or thermocouples
- 2 x Speed inputs
Update rate 100 Hz, resolution 12 bit
Programmable trigger levels, ability to measure frequency, period or pulse width.
The voltages from these inputs can also be logged directly as separate channels, allowing the user to see the waveform of the sensor signal

Communications

- 1 x CAN at 1 Mb/s bus speed

Physical

- Case size 48 x 90 x 26.2 mm excluding connector
- Weight 150 gram

Connectors

- 1 x 55 pin Autosport connector for sensor connection
- 1 x 5 pin Autosport connector for power and communications

Item Number	Description
M SVIM	SYNCHRONOUS VERSATILE INPUT MODULE

E888 / E816

The E816 and E888 Expander modules are designed to increase the I/O (input/output) capacity of MoTeC products.

With CAN connectivity and a number of configurable inputs and outputs, they provide customers with greater flexibility to add sensors, customise channels and control more auxiliary functions.

The E888 and E816 expander inputs have medium resolution and update rate, where higher update rates or resolution are required consider using the VIM input expander.



Item Number	Description
M E888	E888 EXPANDER
M E816	E816 EXPANDER

Compatible with

SDL3 - only 8 thermocouples on E888

ADL3 / EDL3 - up to two E888 or E816

ACL - up to two E888 or E816

M400, M600, M800, M880 - one E888 or E816

Depending on the application, some limitations may apply when using an expander with these ECUs. Please check with your dealer for details.

Inputs

E888

8 x analogue voltage inputs, 10 bit (4.9 mV) resolution
0 to 5 V, suitable for potentiometers, voltage output sensors and variable resistance (temperature) sensors

8 x thermocouple inputs, 1 °C resolution

Suits K type thermocouples (-200 to 1250 °C)

2 x cold junction compensation thermistor inputs

4 x digital inputs with frequency measurement and switched capability

2 x switch inputs

Update rate for all inputs 200 Hz, for a second expander 50 Hz

E816

16 x analogue voltage inputs, 10 bit (4.9 mV) resolution

0 to 5 V, suitable for potentiometers, voltage output sensors and variable resistance (temperature) sensors

2 x general purpose temperature inputs, calibrated as Bosch water temperature sensors

4 x digital inputs with frequency measurement and switched capability

2 x switch inputs

Update rate for all inputs 200 Hz, for a second expander 50 Hz

Outputs

8 x PWM outputs

Individually controllable for frequency and duty cycle.

4 x adjustable duty cycle 0 to 100% in 255 steps and frequency range from 8 Hz to 5 kHz

4 x adjustable duty cycle 0 to 100% in 20 steps and frequency range from 1 Hz to 100 Hz

Communications

CAN bus used for communicating to the data acquisition, display or ECU and to the PC during calibration and firmware upgrades

Configuration

Configured as part of the configuration for the connected ECU or data logger.

Physical

Case size 99 x 105 x 40 mm

Weight

E888 310 gram

E816 320 gram

Connectors

E888 two part 60 pin waterproof connector with gold plated contacts

E816 66 pin Autosport connector

Ignition Expander

The Ignition Expander module (IEX) is designed to increase the ignition output capacity of MoTeC ECUs.

The IEX connects to a single ignition output on the ECU and can drive up to 8 ignition modules. For 10 and 12 coil applications, two IEX units can be used.

Note: that the IEX does not drive the coil directly, an ignition module is still required.



Item Number	Description
M IGN EX	IGNITION EXPANDER
M IGN EX AS	IGNITION EXPANDER W/AUTOSPORT

Compatible with

All MoTeC ECUs

Outputs

8 x ignition outputs

Suits most ignition modules of falling edge type

The dwell time is controlled by the ECU

For 10 and 12 coil applications, two IEX units can be used

Communications

MoTeC specific coded signal supplied from a single ignition output on the ECU

Physical

Case size 70 x 100 x 35 mm

Weight 220 gram

Connector Type (Choose one of the following)

18 pin waterproof connector with gold plated contacts

22 pin Autosport connector

Traction Control Multiplexer

The Traction Control Multiplexer (TCMux) is designed to increase the speed inputs into a MoTeC ECU.

It takes four individual wheel speed signals and turns them into one coded signal for an ECU to read as driven speed (wheels that have power), undriven speed (rolling wheels) and slip (percentage difference between driven and undriven wheels).

A TCMux is not a stand-alone device.



Item Number	Description
M TC MUX	TRACTION CONTROL MULTIPLEXER

Compatible with

All MoTeC ECUs

Inputs

4 x Digital/speed inputs

Communications

MoTeC specific coded signal supplied to an ECU digital/speed input

Physical

Case size 70 x 100 x 35 mm excluding connector

Weight 215 gram

1x18 pin waterproof connector with gold plated contacts

Lambda

Lambda To CAN (LTC)

MoTeC's LTC (Lambda to CAN) modules monitor, control and diagnose Bosch LSU 4.9 Lambda sensors, transmitting readings on a CAN bus. When multiple LTCs are used, up to 32 Lambda sensors can be configured on a single CAN bus, allowing an ECU or logging device to simultaneously monitor numerous Lambda sensors.

NOTE: MoTeC's LTC is also available in a dual version, LTCD



Sensors compatibility

Bosch LSU 4.9, 5 wire sensor

Inputs/Outputs

1 x Bosch LSU 4.9 Lambda sensor
 Power supply voltage 11 V – 16 V
 Power supply current 110 mA typical plus the sensor heater current (heater current is typically 0.5 A – 1 A and up to 2 A on startup)

Communications

1 x CAN at 1 Mbit/sec

Connectors

1 x 4 pin male DTM connector (power/CAN)
 1 x mating connector for Bosch LSU 4.9 sensor

Physical

Dimensions 38 x 26 x 14 mm excluding wiring looms and connectors
 Weight 62 grams
 Maximum ambient temperature 100 °C

General

Provides accurate Lambda measurement even when exhaust gas temperature is changing rapidly (heating or cooling)
 Calibrated by the user for a particular sensor using either the initial sensor factory calibration or a free air calibration
 Install as a single unit or in multiples
 Pre-configured to suit a single LTC unit installation
 Cost effective

Measurement/Configuration

Compatible fuel:
 gasoline/petrol
 alcohol
 LPG
 diesel
 user defined 'blend' fuel
 Comprehensive diagnostic and status channels
 Calibration methods:
 automatic, using the sensor's built-in calibration resistor
 known oxygen environment
 Standard configuration tables
 Configurable to compensate for sensor aging and contamination
 Accuracy +/- 1.5%

Operating range:

Lambda 0.65 to 10
 AFR 9.5 to 147 for gasoline/petrol

Item Number	Description
M LTC	LAMBDA TO CAN

Lambda To CAN Dual (LTCD)

MoTeC's LTCD (Lambda to CAN Dual) modules monitor, control and diagnose Bosch LSU 4.9 Lambda sensors, transmitting readings on a CAN bus. When multiple LTCDs are used, up to 32 Lambda sensors can be configured on a single CAN bus, allowing an ECU or logging device to simultaneously monitor numerous Lambda sensors.

NOTE: MoTeC's LTCD is also available in a singular version, LTC



Sensors compatibility

Bosch LSU 4.9, 5 wire sensor

Inputs/Outputs

1 x Bosch LSU 4.9 Lambda sensor

Power supply voltage 11 V – 16 V

Power supply current 110 mA typical plus the sensor heater current (heater current is typically 0.5 A – 1 A and up to 2 A on startup)

Communications

1 x CAN at 1 Mbit/sec

Connectors

1 x 4 pin male DTM connector (power/CAN)

2 x mating connector for Bosch LSU 4.9 sensor

Physical

Dimensions 38 x 26 x 23.5 mm excluding wiring looms and connectors

Weight 100 grams

Maximum ambient temperature 100 °C

General

Provides accurate Lambda measurement even when exhaust gas temperature is changing rapidly (heating or cooling)

Calibrated by the user for a particular sensor using either the initial sensor factory calibration or a free air calibration

Install as a single unit or in multiples

Pre-configured to suit a single LTCD unit installation

Cost effective

Measurement/Configuration

Compatible fuel:

gasoline/petrol

alcohol

LPG

diesel

user defined 'blend' fuel

Comprehensive diagnostic and status channels

Calibration methods:

automatic, using the sensor's built-in calibration resistor

known oxygen environment

Standard configuration tables

Configurable to compensate for sensor aging and contamination

Accuracy +/- 1.5%

Operating range:

Lambda 0.65 to 10

AFR 9.5 to 147 for gasoline/petrol

Item Number	Description
M LTCD	LAMBDA TO CAN DUAL

Lambda To CAN (LTC NTK)

MoTeC's LTC NTK (Lambda to CAN) modules monitor, control and diagnose NTK Lambda sensors, transmitting readings on a CAN bus. When multiple LTC NTKs are used, up to 32 Lambda sensors can be configured on a single CAN bus, allowing an ECU or logging device to simultaneously monitor numerous Lambda sensors.

NOTE: MoTeC's LTC NTK is also available in a dual version, LTCD NTK



Sensors compatibility

NTK, 5 wire sensor

Inputs/Outputs

1 x NTK Lambda sensor (MoTeC #57007)

Power supply voltage 11 V – 16 V

Power supply current 110 mA typical plus the sensor heater current (heater current is typically 0.5 A – 1 A and up to 2 A on startup)

Communications

1 x CAN at 1 Mbit/sec

Connectors

1 x 4 pin male DTM connector (power/CAN)

1 x mating connector for NTK Lambda sensor

Physical

Dimensions 38 x 26 x 14 mm excluding wiring looms and connectors

Weight 62 grams

Maximum ambient temperature 100 °C

General

Provides accurate Lambda measurement even when exhaust gas temperature is changing rapidly (heating or cooling)

Calibrated by the user for a particular sensor using either the initial sensor factory calibration or a free air calibration

Install as a single unit or in multiples

Pre-configured to suit a single LTC NTK unit installation

Cost effective

Measurement/Configuration

Compatible fuel:

gasoline/petrol

alcohol

LPG

diesel

user defined 'blend' fuel

Comprehensive diagnostic and status channels

Calibration methods:

automatic, using the sensor's built-in calibration resistor

known oxygen environment

Standard configuration tables

Configurable to compensate for sensor aging and

contamination

Accuracy +/- 1.5%

Operating range:

Lambda 0.65 to 10

AFR 9.5 to 147 for gasoline/petrol

Item Number	Description
M LTC NTK	LAMBDA TO CAN NTK

Lambda To CAN Dual (LTCD NTK)

MoTeC's LTC NTK (Lambda to CAN) modules monitor, control and diagnose NTK Lambda sensors, transmitting readings on a CAN bus. When multiple LTC NTKs are used, up to 32 Lambda sensors can be configured on a single CAN bus, allowing an ECU or logging device to simultaneously monitor numerous Lambda sensors.

NOTE: MoTeC's LTC NTK is also available in a dual version, LTCD NTK



Sensors compatibility

NTK, 5 wire sensor

Inputs/Outputs

2 x NTK Lambda sensors (MoTeC #57007)

Power supply voltage 11 V – 16 V

Power supply current 110 mA typical plus the sensor heater current (heater current is typically 0.5 A – 1 A and up to 2 A on startup)

Communications

1 x CAN at 1 Mbit/sec

Connectors

1 x 4 pin male DTM connector (power/CAN)

2 x mating connectors for NTK Lambda sensors

Physical

Dimensions 38 x 26 x 23.5 mm excluding wiring looms and connectors

Weight 100 grams

Maximum ambient temperature 100 °C

General

Provides accurate Lambda measurement even when exhaust gas temperature is changing rapidly (heating or cooling)

Calibrated by the user for a particular sensor using either the initial sensor factory calibration or a free air calibration

Install as a single unit or in multiples

Pre-configured to suit a single LTCD NTK unit installation

Cost effective

Measurement/Configuration

Compatible fuel:

gasoline/petrol

alcohol

LPG

diesel

user defined 'blend' fuel

Comprehensive diagnostic and status channels

Calibration methods:

automatic, using the sensor's built-in calibration resistor

known oxygen environment

Standard configuration tables

Configurable to compensate for sensor aging and contamination

Accuracy +/- 1.5%

Operating range:

Lambda 0.65 to 10

AFR 9.5 to 147 for gasoline/petrol

Item Number	Description
M LTCD NTK	LAMBDA TO CAN DUAL NTK

Professional Lambda Meter (PLM)

The MoTeC Professional Lambda Meter (PLM) determines exhaust gas mixture strength over a wide range of conditions with a fast response time. Quick and easy to use, it allows a calibration engineer all the power and configurability required for OE emissions development and certification work.

The MoTeC PLM provides a differential analog-voltage output that connects to an analog meter or measurement instrument such as data logger or chart recorder. Define output as linear or non-linear in relation to the measured units. The PLM also supports 1mbit CAN and RS232 data links to devices such as the MoTeC dash/logger for transmission of sensor and diagnostic data. Comprehensive diagnostic, status channels are provided for.

The PLM can be used as Lambda input for an ECU! Instead of purchasing the Lambda Upgrade on M4/M48 - the PLM's definable output voltage can be used as the input for Lambda on these ECU's. This gives you the use of a more state of the art sensor with a digital display which you can place on your dashboard for viewing even if the ECU is offline. Of course you can then use this lambda meter on any other car you wish.



Specifications:

- Weighs 135 gms
- Robust aluminum enclosure
- Operating range 0.70 and 32.0 lambda (for gasoline/petrol this equals air/fuel ratio range of 10.3:1 to 470:1)
- Display lambda, air/fuel ratio, or oxygen percentage for any sensor-compatible fuel
- Define display resolution (in decimal points), update rate, filtering, backlight intensity
- Easy Air calibration using PLM Software (no twisting of screws or watching LED's required)

Item Number	Description
M PLM	PROFESSIONAL LAMBDA METER

Kits come with Sensor, Harness, Software, O2 Bung, Comm Cable and Users Manual

Professional Lambda Meter Accessories



Item Number	Description
M PLM CIG	CIGARETTE LIGHTER ADAPTER
TR-18 PLUG	18MM X 1.5MM THREADED SATAINLESS BUNG W/COPPER WASHER
TR-18-13	18MM SS RING FOR LSU SENSOR
TR-18 SS	OXY SENSOR RING 304L STAINLESS
M PLM EXT	20' PLM EXTENSION CABLE

Power

PDM16

MoTeC's 16 output Power Distribution Module (PDM16) is designed to provide electronically switched power to the various electrical systems in the vehicle such as motors, lights and solenoids, and electronic devices such as ECUs and data acquisition systems.

The module replaces conventional relays, fuses and circuit breakers, simplifying wiring and reducing weight while increasing reliability.



Item Number	Description
M PDM16	POWER DISTRIBUTION MODULE

Outputs

- 8 x 20 A outputs—20 A continuous, 115 A transient (typical)
- 8 x 8 A outputs—8 A continuous, 60 A transient (typical)

Inputs

- 12 x Switch inputs

Communications

- 1 x CAN

Diagnostic Information

- Output current and voltages
- Input voltages
- Error status

Physical

- Connectors
 - 1 x 26 pin Autosport connector
 - 1 x 1 pin Autosport connector
 - 1 x 8 pin Autosport connector
- Case size 130 x 60 x 28 mm
- Weight 300 grams

General Features

- Each output is over-current, short circuit and thermal overload protected
- Outputs programmable in 1 A steps
- Outputs controllable via a combination of switch inputs, CAN messages and logic functions
- Switch inputs ranging from 0 to 51 V, resolution 0.2 V
- Performing up to 200 logic operations using operators like Flash, Pulse, Set/Reset, Hysteresis, Toggle, And, Or, Less than, Greater than, Not equal to, Equal to, True, False etc.
- Performing functions such as flashing indicator lights and controlling thermofan and fuel pump
- Using logic functions to selectively turn off systems during low battery voltage or engine starting, reducing drain on the battery
- Providing full diagnostic information, including output currents and voltages, input voltages, and error status
- Transmitting diagnostic information via CAN to a display or data logging device or monitoring directly on a PC

PDM32

MoTeC's 32 output Power Distribution Module (PDM32) is designed to provide electronically switched power to the various electrical systems in the vehicle such as motors, lights and solenoids, and electronic devices such as ECUs and data acquisition systems.

The module replaces conventional relays, fuses and circuit breakers, simplifying wiring and reducing weight while increasing reliability.



Item Number	Description
M PDM32	POWER DISTRIBUTION MODULE

Outputs

8 x 20 A outputs - 20 A continuous, 115 A transient (typical)
24 x 8 A outputs - 8 A continuous, 60 A transient (typical)

Inputs

23 x Switch inputs

Communications

1 x CAN

Diagnostic Information

Output current and voltages
Input voltages
Error status

Physical

Connectors
1 x 37 pin Autosport connector
1 x 26 pin Autosport connector
1 x 1 pin Autosport connector
1 x 8 pin Autosport connector
Case size 180 x 60 x 28 mm
Weight 405 grams

General Features

Each output is over-current, short circuit and thermal overload protected
Outputs programmable in 1 A steps
Outputs controllable via a combination of switch inputs, CAN messages and logic functions
Switch inputs ranging from 0 to 51 V, resolution 0.2 V
Performing up to 200 logic operations using operators like Flash, Pulse, Set/Reset, Hysteresis, Toggle, And, Or, Less than, Greater than, Not equal to, Equal to, True, False etc.
Performing functions such as flashing indicator lights and controlling thermofan and fuel pump
Using logic functions to selectively turn off systems during low battery voltage or engine starting, reducing drain on the battery
Providing full diagnostic information, including output currents and voltages, input voltages, and error status
Transmitting diagnostic information via CAN to a display or data logging device or monitoring directly on a PC

PDM15

MoTeC's 15 output Power Distribution Module (PDM15) is designed to provide electronically switched power to the various electrical systems in the vehicle such as motors, lights and solenoids, and electronic devices such as ECUs and data acquisition systems.

The module replaces conventional relays, fuses and circuit breakers, simplifying wiring and reducing weight while increasing reliability.



Item Number	Description
M PDM15	POWER DISTRIBUTION MODULE

Outputs

8 x 20 A outputs - 20 A continuous, 115 A transient (typical)
7 x 8 A outputs - 8 A continuous, 60 A transient (typical)

Inputs

16 x Switch inputs

Communications

1 x CAN

Diagnostic Information

Output current and voltages
Input voltages
Error status

Physical

Connectors
1 x 34 pin waterproof connector
1 x 26 pin waterproof connector
1 x M6 stud
Case size 108 x 128 x 39 mm
Weight 260 grams

General Features

Each output is over-current, short circuit and thermal overload protected
Outputs programmable in 1 A steps
Outputs controllable via a combination of switch inputs, CAN messages and logic functions
Switch inputs ranging from 0 to 51 V, resolution 0.2 V
Performing up to 200 logic operations using operators like Flash, Pulse, Set/Reset, Hysteresis, Toggle, And, Or, Less than, Greater than, Not equal to, Equal to, True, False etc.
Performing functions such as flashing indicator lights and controlling thermofan and fuel pump
Using logic functions to selectively turn off systems during low battery voltage or engine starting, reducing drain on the battery
Providing full diagnostic information, including output currents and voltages, input voltages, and error status
Transmitting diagnostic information via CAN to a display or data logging device or monitoring directly on a PC

PDM30

MoTeC's 30 output Power Distribution Module (PDM30) is designed to provide electronically switched power to the various electrical systems in the vehicle such as motors, lights and solenoids, and electronic devices such as ECUs and data acquisition systems.

The module replaces conventional relays, fuses and circuit breakers, simplifying wiring and reducing weight, while increasing reliability.



Item Number	Description
M PDM30	POWER DISTRIBUTION MODULE

Outputs

8 x 20 A outputs - 20 A continuous, 115 A transient (typical)
22 x 8 A outputs - 8 A continuous, 60 A transient (typical)

Inputs

16 x Switch inputs

Communications

1 x CAN

Diagnostic Information

Output current and voltages
Input voltages
Error status

Physical

Connectors
1 x 34 pin waterproof connector
1 x 26 pin waterproof connector
1 x M6 stud
Case size 108 x 128 x 39 mm
Weight 270 grams

General Features

Each output is over-current, short circuit and thermal overload protected
Outputs programmable in 1 A steps
Outputs controllable via a combination of switch inputs, CAN messages and logic functions
Switch inputs ranging from 0 to 51 V, resolution 0.2 V
Performing up to 200 logic operations using operators like Flash, Pulse, Set/Reset, Hysteresis, Toggle, And, Or, Less than, Greater than, Not equal to, Equal to, True, False etc.
Performing functions such as flashing indicator lights and controlling thermofan and fuel pump
Using logic functions to selectively turn off systems during low battery voltage or engine starting, reducing drain on the battery
Providing full diagnostic information, including output currents and voltages, input voltages, and error status
Transmitting diagnostic information via CAN to a display or data logging device or monitoring directly on a PC

Dual Half Bridge (DHB)

The Dual Half Bridge (DHB) is a high current amplifier which allows low current auxiliary outputs to drive high current loads such as motors. It contains two high current half bridge outputs enabling it to drive a single motor in two directions, or drive two motors in a single direction. It is also capable of high speed PWM, which can be used for speed control of motors and for other purposes.

The DHB connects to any auxiliary output of a MoTeC ECU or Dash Logger, which performs the control function, such as PWM speed control, direction control or servo control.

The fully sealed case makes the DHB suitable for under bonnet mounting.

Application Examples

- Servo motor e.g. active wing control, boat trim control, inlet runner length control, variable valve lift.
- Motor speed control e.g. electric water pump, thermo fan, fuel pump.
- Solenoid control.



Item Number	Description
M DHB	DUAL HALF BRIDGE

Compatible with

All MoTeC ECUs
All MoTeC Dash Loggers

Basic Specifications

Electrical

Output current
Continuous DC current 20 A (total)
Peak surge current 500 A
Max. operating frequency 50 kHz @ 28 V
Switching delay, typical
High to low 6.5 µsec
Low to high 6.5 µsec
Input threshold, typical
High 2.8 V
Low 2.1 V

Operating voltage

7.0 V to 55 V with under voltage lockout

Physical

Size 31.4 x 38.0 x 14.0 mm
Weight approximately 60 grams plus connectors
Connectors
Power: 2 pin DTP Male
Motor /Output: 2 pin DTP Female
Input: 2 pin DTM Male
Maximum case temperature 125 °C

Ignition

Capacitive-Discharge Ignitions

For Single and Dual coil CDI applications using conventional distributed spark or for Rotary applications, We recommend our proven single and dual channel CDI boxes. Over 100 millijoules of energy is available per spark and the hardware is produced to hang tough under this kind of operating condition in a racing environment.



Item Number	Description
M CDI-1 M&W	M&W 1 CH
M CDI-2 M&W	M&W 2 CH
M CDI-4 M&W	M&W 4 CH
M CDI-8	MOTEC 8 CH
M CDI-8 M1	MOTEC 8 CH FOR M1 ECU'S



The MoTeC CDI-8 answers the call for world-class ignition capability in a compact, rugged package. Designed to drive up to eight low-impedance CDI coils. The CDI-8 can operate in ECU slave mode or in stand-alone mode with Windows spark-mapping software. The CDI-8 boast features like Autosport connectors and CAN-based diagnostics.

Reliable, refined circuitry can deliver full 450-volt primary voltage at 15,000 revs (30,000 RPM for 4 cyl). Output stages can deliver up to 200 amps into a CDI coil primary without damage. CDI links into the vehicle network CAN bus to provide instant diagnostic messaging. Simply the best CDI available anywhere. CDI-8 has been proven on engines producing more than 3000 Horsepower.



Capacitive-Discharge Ignitions Accessories

CDI-8 Wiring



Item Number	Description
M CDI-8H	10' UNTERMINATED HARNESS

Item Number	Description
M 4-2100	4-CYL COIL PACK W/INTEGRAL IGNITORS

Multi Coil Inductive



Capacitive-Discharge Coils

Item Number	Description
M CDI 551 101	SINGLE ENDED CDI COIL
M CDI 551 102	DOUBLE ENDED CDI COIL



Capacitive-Discharge Ignitions Accessories

Coil Near Plug Inductive



Item Number	Description
M DEN 580	COIL-NEAR PLUG W/INTEGRAL IGNITOR
M DEN 580 WIRE	DENSO 580 PRODUCTION SPARK PLUG WIRE
M DEN 580 TERM	DENSO 580 TERMINATION KIT

Denso Termination

Item Number	Description
M 12-2254	STRAIGHT COIL-END BOOT
M 12-3659	45° COIL-END BOOT
M 12-2220	90° COIL-END BOOT
M 12-2264	STRAIGHT SPARK PLUG BOOTS



Item Number	Description
M 12-2977	COIL-END TERMINATION
M 015561	7MM SPARK PLUG WIRE



Like Thunder and Lightning

The Denso 580 Coil Near Plug features a built in Ignitor making them an excellent choice for ignition because they eliminate the need for an external ignitor between the ECU or Ignition Expander and the coil. Do they have a good spark? We have had success using them to ignite the spark under 20 PSI boost on some 2000 Hp Engines!

RaceGrade High Output Ignition Coil (IGN1A)

The RaceGrade High Output Ignition Coil is an inductive 'smart coil' capable of producing extremely high spark energy (103mJ +) making it ideal for many high horsepower applications. The coil-near-plug form factor allows it to be remotely mounted away from the cylinder head to promote lower operating temperatures of the coil, improving longevity and performance. The RaceGrade High Output Ignition Coil is ideally suited for a wide variety of applications, ranging from moderate powered endurance applications through 3000+ horsepower blown alcohol motors. It is the ideal combination of high spark energy and long spark duration.

Field proven for exceptional reliability and performance, the RaceGrade High Output Ignition Coil's built-in igniter allows for a simplified installation and is ideal for use with all MoTeC ECU's (and most other brands). No external igniter or CDI is required for these coil to function.

When installing the RaceGrade High Output Ignition Coil, special attention must be paid to the quality of the connections due to the immense energy of this coil. The center pin (Terminal C) **MUST** be grounded to the cylinder head. The coil will not supply full power if it is not grounded to the cylinder head. Please refer to the Characteristic Dwell Time chart listed below. The coil will overheat if operated at excessive duty cycles for prolonged periods. Do not operate this coil at a duty cycle greater than 40%.



Item Number	Description
M IGN1A	IGN COIL W/BUILT-IN IGNITOR

Connection

- A: Coil Trigger (ECU Trigger)
- B: Coil Trigger (ECU 0V)
- C: GND to Cyl Head
- D: Battery GND
- E: Battery POS

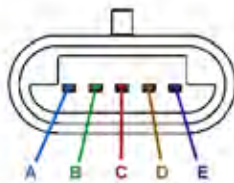

Mating Connector: M 12-2825 (included)

I _{Primary}	V _{Battery}						
	6 V	8 V	10 V	12 V	14 V	16 V	18 V
4 A	6.7	4.6	3.4	2.7	2.3	1.9	1.6
6 A	12.4	7.7	5.6	4.3	3.6	3	2.6
8 A	22	10.8	7.5	5.8	4.8	3.9	3.5
10 A		13.5	8.9	6.7	5.5	4.6	3.9
12 A			10.3	7.4	5.9	4.9	4.3
14 A				8.4	6.4	5.3	4.5
16 A						5.8	4.9

Note: The connector is a 'pull to seat' connector. The wires must be fed through the connector before termination.

Multi-Channel Ignitors

Item Number	Description
M 0227 124 D	BOSCH 1-CHANNEL IGNITOR
M 0227 200	BOSCH 2-CHANNEL IGNITOR



Item Number	Description
M 0227 203	BOSCH 3-CHANNEL IGNITOR
M 0227 211	BOSCH 4-CHANNEL IGNITOR



Why Do I need an Ignitor - what do they do?

An ignitor is an amplifier that converts a low current signal into a high current signal. In this case the coil trigger signal coming from the ECU is low current. The ignitor uses this low current signal to trigger the coil itself which requires high current.

Why doesnt the MoTeC have a built in ignitor?

Since the part that actually triggers the coils is a high current device, it gets extremely hot during normal operation. That heat when placed in close proximity to the sophisticated microprocessor controlling your engine can cause it to degrade over time. Also, should the ignitor ever fail - it can be easily accessed for replacement - no need to send the ECU in for repair. Lastly, without the constraints of a built in ignitor MoTeC gives you the freedom to trigger any type of ignition system making integration with your existing hardware as seamless as possible.

Lap Timing

BR2 Receiver

The Beacon Receiver (BR2) is the part of the lap timing system that is fitted in the vehicle. Depending on the other components in the application, the receiver can be connected using a switched output or a CAN bus and should be set up accordingly.

Fitting the BR2

The BR2 should be fitted so that the infra red beam hits the receiver window at a right angle when the car passes the transmitter.

If there are no obstacles between transmitter and receiver, the range of MoTeC's lap timing system is up to 40 meters. The receiver should be positioned carefully in the vehicle to avoid the beam passing through tinted glass or acrylic, which can reduce the range substantially.



Item Number	Description
M ADL BRX-2	BEACON RECEIVER

Compatible with

SDL3
ADL3
ACL
MDD
M400/M600/M800/M880

Specifications

Outputs

LED indicating
Power on
Beacon signal received
Error codes
Digital output for beacon information (alternative to CAN output)

Communications

CAN bus used for
communicating beacon information
communicating diagnostic information
configuring the receiver via the BR2 configuration software

Physical

5 pin Autosport connector
Case size 75 x 36.5 x 25 mm

BTX Transmitter

The Beacon Transmitter (BTX) is the track side mounted part of the lap timing system.

Mounting the BTX

The narrow infrared beam emitted by the BTX should be aimed parallel to the road and at the same height above the road as the receiver in the vehicle. The transmitter mounting system should therefore be capable of height and tilt adjustment.

The spacing between adjacent transmitters must be at least 6 meters.



<i>Item Number</i>	<i>Description</i>
M ADL BTX	BEACON TRANSMITER

Compatible with

BR2

Specifications

Output

- Coded infrared beam
- Range up to 40 meter (130 ft) when used with BR2
- Status indicator
- LED in three colours indicating:
 - Power OK
 - Low battery
 - Fault or very low battery

Power

- External via a 12 volt rechargeable battery (10 Ahr capacity recommended)
- Power consumption 70 mA typical

Physical

- Case size 90 x 80 x 115 mm
- Weight 260 gram

MoTeC GPS

The GPS-L5 (5 Hz GPS) and GPS-10 (10 Hz GPS) combine their electronics and antenna into one small unit. A highly sensitive receiver allows the GPS to lock onto signals even in difficult environments. Both are fitted with a DTM connector and are pre-configured to be compatible with the following devices:

GPS-L5 is Compatible with

- MoTeC 'Hundred Series' ECUs - M400, M600, M800, M880 (v3.51U2 and up)
- MoTeC M84 ECU (v1.10K2 and up)
- MoTeC ACL
- MoTeC ADL3, ADL2 (not compatible with original ADLs)
- MoTeC SDL3, SDL

GPS-L10 is Compatible with

- MoTeC ACL
- MoTeC ADL3, ADL2 (not compatible with original ADLs)
- MoTeC SDL3, SDL

Note: *Not compatible with MoTeC ECU's*

Both units are suitable for speed, position and lap timing.



Performance

GPS-L5

Update rate 5 Hz

GPS-L10

Update rate 10 Hz

66 satellite channels

Start Up Times

Cold - 35 seconds

Warm - 33 seconds

Hot - 2 seconds

Reacquisition Time - <1 second

Dynamics 4 G

Power supply voltage 4.0 – 6.0 V

Communications

RS232

GPS-L5

Baud rate: 19200

GPS-L10

Baud rate: 38400

Physical

Case size 48 mm x 41 mm x 14 mm

Weight 106 g

1 x 4 pin Deutsch DTM, 3 m flying lead

Built in antenna

Mounting - magnetic base

Item Number	Description
M GPS-L5	5Hz GPS FOR ECU's
M GPS-L10	10Hz GPS FOR LOGGERS

RaceGrade GPS Radio

The M GPS BL is a 10 Hz GPS which can be upgraded to 20 Hz. The advanced GPS receiver rejects all multi-path signals to ensure accuracy.

It is enclosed in a motorsport aluminium case with a serial output conforming to NMEA standard RS-232 protocol at 57600 baud rate and a speed output for applications that do not accept serial data. It can also be ordered with an optional CAN output.

It is well suited to MoTeC Dash/Data Loggers, and the 10 Hz model may also be pre-configured upon request for use with MoTeC M1 series, 'Hundred Series' and M84 ECUs.

The new improved version is smaller and lighter. It incorporates a foam seal to protect it from the environment and floating circuit board design to be more vibration resistant. It also potted with RaceGrade RaceGel for improved resistance to vibration and the environment. The connections are now all on the top surface to improve flexibility in mounting arrangement. The main connector was changed to utilize a smaller, lighter and more common Autosport connector.

This unit is suitable for speed, position and lap timing.

Compatible with

- C125
- C185
- ACL
- ADL3, ADL2
- SDL3, SDL
- By request: MoTeC ECUs - M150, M170, M190, M142, M182, M400, M600, M800, M880, M84

Note: this unit can be ordered with a 5 Hz update rate for those that need better accuracy with an ECU



Performance

Update rate 10 Hz, upgradable to 20 Hz
 12 satellite channels
 Horizontal accuracy < 0.7 meter at 95% with DGPS
 Power supply voltage 6–18 V
 SBAS and WAAS corrections for higher accuracy

Communications

RS232 serial at 57600 baud rate formatted NMEA GGA and RMC messages. Other baud rates and/or message types available upon request.
 CAN output for MoTeC devices (bus speed is 1 Mbit/s)

Physical

Case size 100 x 60 x 23 mm
 3.95 x 2.35 x 0.9 in)
 Weight 230 gram
 Connector
 1 x 5 pin Autosport connector
 1 x SMA connector for antenna

Item Number	Description
M GPS BL V3	VER 3 GPS 10Hz

Sensors

Temperature Sensors

Air Temp

Item Number	Description
M 25-7225	AIR, NTC AC SPECIAL
M 0280 060	AIR, NTC 12MM LONG REACH
M 0280 039	AIR, NTC 12MM



Liquid Temp

Item Number	Description
M 0280 026	COOLANT, M12x1.5
M 0280 026M	COOLANT, 1/8 NPT
M 25-5227	COOLANT, 3/8 NPT
M 25-2197 D	1/8 STAINLESS PIPE WITH FLYING LEAD



Head Temp

Item Number	Description
M 0280 059	CYLINDER-HEAD, M12x1.00 LH
M 0280 070	CYLINDER-HEAD, M10x1.00 RH



Exhaust Temp

Item Number	Description
M TCA	THERMOCOUPLE AMPLIFIER
M TC2C	1/8" CLOSED END 90 DEG
M TC SS20012WBT	1/8" K-TYPE STAINLESS BUNG
M TC4C	1/4" CLOSED END 90 DEG
M TC4C-ST	1/4" CLOSED END STRAIGHT
M TC SS40064WBT	1/4" K-TYPE STAINLESS BUNG



Tip:

Exhaust-temp measurement has never been easier or more affordable.

Thermocouple amplifiers can drive past either a temp input or an analog voltage input making them easy to configure into your system.

Open Ended or Closed Ended?

Open ended sensors react faster than closed ended sensors, however they do not last as long. What you gain in response time you give up in longevity.

Crank & Speed Sensors

Crank/Cam Trigger

Item Number	Description
M 3025 SS13	CRANK, 3/8" 2 ² SMOOTH MAG SENSOR
M 6-BAC-AD8	CRANK ANGLE, GM MAG SENSOR
M 4-APX-001	CRANK, 3/8" 2 ² THREADED MAG SENSOR



Item Number	Description
M 6-APX-003	CRANK, 5/8" 2 ² THREADED MAG SENSOR
M MHALL 437	CRANK/CAM, MAGNET OPERATED
M MHALL MAG ASB	SAMARIUM/COBALT MAGNET, 1/4 THD CARRIER
M MHALL MAG	SAMARIUM/COBALT .115" DIAMETER, WHITE=SOUTH POLE



Dual Magnetic Converter

Item Number	For Use With
M DMC A	FUEL FLOW SENSORS
M DMC B	ENGINE TRIGGER SENSORS
M DMC C	IGNITION SYSTEM INPUT CONDITIONERS
M DMC D	MAGNETIC WHEEL SPEED SENSORS

The Dual Magnetic Converter (DMC) converts magnetic style signals to open collector output signals – a square wave.



Wheel Speed

Item Number	Description
M DHALL 437	7/16 THREADED HALL SENSOR
M GT101DC	GT101 HALL EFFECT



Position Sensors

String Potentiometers



Item Number	Description
M ADL SPOT 10	STRING POTENTIOMETER

Fluid level

Electronic Sending Unit For Fuel, Oil, and Potable Water

Length = 14-inches
Output Voltage = 0-5 volts



Item Number	Description
M P155-CGO-14	FLUID LEVEL SENSOR

Linear Position



Standard termination is with DTM connectors

Item Number	Description
M LPS 50	50MM LINEAR POSITION SENSOR
M LPS 75	75MM LINEAR POSITION SENSOR
M LPS 100	100MM LINEAR POSITION SENSOR
M LPS 150	150MM LINEAR POSITION SENSOR
M LPS 200	200MM LINEAR POSITION SENSOR

Throttle Angle



Item Number	Description
M 0280 001	BOSCH, D DRIVE CLOCKWISE
M 580-06751	NONCONTACT HALL CLOCKWISE
M 518-1	D DRIVE COUNTERCLOCKWISE
M 518-3	D DRIVE CLOCKWISE

Pressure Sensors

MoTeC



<i>Item Number</i>	<i>Description</i>
M KP41 100G	100 PSI PRESSURE TRANSDUCER
M KP41 150G	150 PSI PRESSURE TRANSDUCER
M KP41 300G	300 PSI PRESSURE TRANSDUCER
M KP41 1000G	1000 PSI PRESSURE TRANSDUCER
M KP41 2000S	2000 PSI PRESSURE TRANSDUCER
M KP41 3000S	3000 PSI PRESSURE TRANSDUCER
M KP45 75A	75 PSIA PRESSURE TRANSDUCER

RaceGrade Autosport



<i>Item Number</i>	<i>Description</i>
M APT-KM42-150	150PSI AS PRESSURE TRANSDUCER
M APT-KM42-2000	2000PSI AS PRESSURE TRANSDUCER

RaceGrade DTM



<i>Item Number</i>	<i>Description</i>
M APT G2 DTM 100	100PSIG DTM TRANSDUCER
M APT G2 DTM 150	150PSIG DTM TRANSDUCER
M APT G2 DTM 200	200PSIG DTM TRANSDUCER
M APT G2 DTM 2000	2000PSIG DTM TRANSDUCER
M APT G3 DTM 60A	60 PSIA DTM PRESS TRANSDUCER
M APT G3 DTM 100A	100 PSIA DTM PRESS TRANSDUCER

Lambda Sensors



LSM-11



LSU-4



UEGO



LSU-4.2



LSU-4.9

Item Number	Description	For Use With
M 0258 002	BOSCH LSM-11 4 WIRE WIDE BAND	M4/M48 ECU's AND MOTEC ADL
M 0258 666	BOSCH LSU-4 5 WIRE WIDE BAND	M800/M880 ECU's AND PLM's
M UEGO SENSOR	NTK UEGO PRO 5 WIRE WIDE BAND	M800/M880 ECU's AND PLM's
M 0258 206	BOSCH LSU-4.2 SENSOR	M800/M880 ECU's AND PLM's
M 0258 001	BOSCH LSU-4.9 SENSOR	M800/M880 ECU's AND PLM's

What is Lambda anyway?

Lambda describes an equivalence value in percentage of the chemically correct air-to-fuel ratio for any type of fuel. If the air fuel ratio measured in the exhaust pipe of an engine is at the chemically correct (stoichiometric) ratio of air-to-fuel, lambda is equal to 1.0. In the case of gasoline, lambda 1.0 is equivalent to 14.7:1 air-to-fuel. Lambdas less than 1.0 indicate the engine is running richer than stoichiometric, while lambdas greater than 1.0 indicate a lean mixture. If we measure a lambda value of 1.06 and we want a lambda value of .95, we simply increase the fuel delivered to the engine (pulsewidth) by 11 percent. This will place us exactly at .95 lambda. By using the Lambda Was or the Quick Lambda functions a tuner can quickly shape the fuel table to match the engine's exact requirements.

How long will the Lambda Sensor Last?

A Lambda sensor is designed as a consumable item which means like a spark plug, it wears out with use. Typically you may notice the sensor begin to slow down in its response to changes in lambda when it becomes worn out. This normally occurs in about 500 hours on unleaded type fuels but is reduced to 50 hours for lead. Like Spark Plugs, the sensor can be fouled in a matter of minutes with improper air fuel ratios and the sensor can crack if it is over torqued or dropped. For this reason, there is no warranty on Lambda Sensors.

RaceGrade TC8 Thermocouple to CAN

A CAN based expansion module that allows for up to 8 thermocouple sensors to be connected. The module works with non-amplified K-type thermocouples only. Version 1.4 of TC8 is capable of being programmed via CAN. This is usefully if you wish to have multiple TC8 on one CAN bus or are using a TC8 with a non Motec product. There are six different modes to choose from. The first four modes (0-3) mimic an E888. Modes four and five let you choose what CAN ID the messages are sent out on.



NOTE: When no sensor is connected to an input, the output reads between 1050 to 1250°C.

Features

Small, lightweight & compact package
Easy to adapt and wire into any vehicle, just 4 wires; power, ground, CAN high and CAN low.
Built in amplifiers for up to 8 channels
Splash protection, but not waterproof

Operating Temperature

Input Temp Range: 0 to 1000°C +/-4°C
Operating Temp Range: -40°C to 120°C

Power

Operating Voltage Range: 9 to 24 vDC
Operating Current Draw: < 0.1 Amps

Physical

Thermocouple Style: K-type only
Dimensions: 3.5" x 2.26" x 1.0"
Weight: 173 grams

Connection:

Mating Connector: ASL606-05SN
Pin 1 – Ground
Pin 2 – N/C
Pin 3 – Power
Pin 4 – CAN Lo
Pin 5 – CAN Hi

CAN Messaging:

CAN Bus speed: 1 Mbps, 500 Kbps, 250 Kbps, 125 Kbps
Setup is done similar to the MoTeC E888.
Channels are configured as E888 thermocouples.
Can be used on Mx00/M1 ecus and all dashes.

Item Number	Description
RG TC8	8 CH THERMOCOUPLE TO CAN

Switches



Item Number	Description
M SW-4JOY	4-POSITION JOYSTICK
M SW 1TL1-1	CENTERED SPDT NONLOCK
M SW 1TL1-1A	SPDT CENTERED



Item Number	Description
M SW 1NT1-2	SPST ONE-POLE ON-OFF
M SW 1NL1-2D	SPST, BOTH POSITIONS LOCKOUT
M SW 1NT1-3F	SPST, ONE-POSITION LOCKOUT



Item Number	Description
M SW 1NT1-6	SPST MOMENTARY
M SW 1NT1-7	SPDT CENTERED MOMENTARY
M SW 4NT1-12A	DPDT, 3 POSITIONS LOCKOUT



Item Number	Description
M SW N1030-2501	GRAY SILICON SWITCH COVER
M SW N1030-2503	YELLOW SILICON SWITCH COVER
M SW N1030-2508	RED SILICON SWITCH COVER

Communication

Ethernet

Motorsport Ethernet Switch

The RaceGrade Ethernet Switch is a ruggedized four port 10/100 Ethernet switch. An Ethernet switch can be used to connect multiple Ethernet devices to a single easy to reach connection port. Common uses would include a digital dash, ECU, telemetry modem, or other Ethernet devices. The water resistant Ethernet switch has four activity lights that blink with data communication on the corresponding port. Lights also flash twice on power up. Each port has a rubber plug that must be replaced when the port is not in use to keep water out of connector. Water-resistant, or standard Ethernet cables will connect and function with this device. In order for the device to be water resistant, the 2 connectors that come with the switch must be used. Water resistant cables may be ordered in 6ft lengths. These feature a water resistant connector on one end and flying lead on the other. This allows the user to integrate it into an existing harness.



Mouse over for larger view

Item Number	Description
RG TC8	8 CH THERMOCOUPLE TO CAN

Specifications:**Operating Temperature**

Operating Temp Range: -40°C to 85°C

Power

Operating Voltage Range: 8 to 32 vDC

Maximum Current Draw: 0.25 Amps

Physical

Dimensions: 6.50" x 2.50" x 1.66"

Weight: 362 grams

Connection:

Mating Connector #1: ASL606-05SN

Pin 1 – Battery Ground

Pin 3 – Battery Positive

Mating Connector #2: M 12-2001

Pin 1 - TX+ (White/Orange)

Pin 2 - TX- (Orange)

Pin 3 - RX+ (White/Green)

Pin 4 - N/A

Pin 5 - N/A

Pin 6 - RX- (Green)

Pin 7 - N/A

Pin 8 - N/A

CAN Adaptors

USB To CAN Adaptor (UTC)

The MoTeC USB to CAN adapter is used to replace the CAN interface cable (P/N M ADL CAN) in instances where a computer needs to use USB rather than a parallel port for communications. Requires ECU manager version 2.3 or Dash manager 3.2 or above.

Software Requirements for compatibility:



Item Number	Description
M UTC	USB TO CAN ADAPTOR

Device	Software Version Required
Hundred Series ECU's	2.30S or later
PDM's	1.0 or later
BR2	1.0.6.2 ‡
DBW4	1.03 or later
SDC's	1.21 or later
MDC	1.22 or later
MDC2	2.0 or later
LTC	1.0 or later
ADL	3.20P or later

‡ This software ships with all data logging manager software

Serial to CAN Adaptor (STC)

The STC (Serial to CAN) adaptor converts RS232 data to CAN and vice versa allowing multiple RS232 devices to be connected to a Data Logger via CAN.

Features

- Resin filled machined anodised aluminium case with through hole fastening
- Flying lead
- Bi-directional
- Converts RS232 to CAN to display and log GPS data —position, true ground speed and GPS beacons— and ECU data
- Converts CAN to RS232 for transmitting telemetry
- Compatible with TTL voltage levels to connect early M4s and all M48s to a Dash Logger

The 2 baud rates currently available are:

- 19200 used for the M GPS-G5
- 57600 used for the M GPS BL



Item Number	Description
M STC	SERIAL TO CAN ADAPTOR

Inputs

Power supply 12 V (9 - 16 VDC)

Communications

1 x RS232

Baud rates: 9600, 19200, 28800, 38400, 57600.

Data Length: 7 or 8

Parity: None, Even or Odd

Stop Bits: 1 or 2

1 x CAN

Configurable address (default 146h)

1Mbit Baud rate

NOTE: RS232 / CAN settings must be specified when ordering. Currently the STC is non-configurable.

Physical

Case size 38 mm x 14 mm x 26 mm *excluding lead*

Trim Switches

Steering-Wheel Switch Assembly

Sport Dash and ADL steering-wheel switches.

For alarm-acknowledge, scrolling alphanumeric display, and ADL mode. Terminates w/ 6-pin DTM

Item Number	Description
M SD SW H	FOR USE WITH SPORT DASH
M ADL SW H	FOR USE WITH ADL



Dashboard Mounted



Item Number	Description
M DS-12	12 POSITION, USER ADJUSTABLE
M DS-11	11 POSITION, USER ADJUSTABLE
M DSM-4	4 POSITION MAP SWITCH, M800 SERIES ECU's †

Boost Control has never been easier

The MoTeC ECU's offer unparalleled levels of boost control. In addition to having feedback type wastegate control, various inputs can be used to regulate boost for certain parameters. For example, when using a wheelspeed input, MoTeC allows boost based on wheelspeed and rpm - or boost based on gear position and rpm. A multiposition trim switch input can be used to allow the driver to manually select the desired boost level on the fly.

How can I use a Trim Switch?

The multiposition trim switch can be used in a number of ways. It is most commonly used to trim fuel or ignition but can also be used to trim boost if the wastegate is ECU controlled or can be used to select 1 of 9 or 11 different RPM limit levels on the fly without a laptop. Ask your MoTeC representative how you can use a trim switch in your application.

† Requires firmware v 3.3 or higher

Comm Cables ECU-PC

Communications Cable for M48 / M8

Item Number	Description
M RS-232 MK 3	6 FOOT HARNESS
M RS-232 MK3 6M	20 FOOT HARNESS



Communications Cable for M4E / M800 / M880

Item Number	Description
M RS-232 M4E	10' RS-232 SERIAL CABLE



Communications Cable for M48 / M8 with ADL

Item Number	Description
M RS-232 MK3 M	ALLOWS ECU DATA TO BE SENT TO ADL



PC parallel-to-CAN cable

Item Number	Description
M ADL CAN	CAN EXTENSION CABLE
M ADL CAN 25'	CAN EXTENSION CABLE 25 FOOT
M ADL CAN 36'	CAN EXTENSION CABLE 36 FOOT
M ADL CAR	CAR-SIDE CAN CABLE



Computer Interface Module

Item Number	Description
M CIM	CONVERTS TTL TO RS-232
M4 CIM H	CONNECTS ECU, ADL, AND PC TO CIM
M48 CIM H	CONNECTS ECU, ADL, AND PC TO CIM



Crimpers

Item Number	Description
M CW-935	W-CRIMPER
BC-1265	BUTTSPLICE CRIMP TOOL

W-crimper



Buttsplice crimp tool

Item Number	Description
M22520/1-01	LARGE MILSPEC AND DTM CRIMPER
M22520/1-02	CRIMP HEAD FOR M 22520/1-01
M22520/2-01	SMALL MILSPEC AND DTM CRIMPER
M22520/2-02	TURRET FOR DTM AND MILSPEC
M22520/2-07	AUTOSPORT 22GA SOCKETS
M22520/2-09	AUTOSPORT 22GA PINS
M22520/2-10	AUTOSPORT 20GA SOCKETS
M 225034	AUTOSPORT MICRO SOCKETS
M 225035	AUTOSPORT MICRO PINS



SMALL



LARGE



Place mouse over crimper to
see a close up



<i>Item Number</i>	<i>Size (GA)</i>	<i>Description</i>
M 12-4254	14-20	WEATHER PACK WITH SEAL CRIMPER
M 12-5270	--	UNIVERSAL CRIMPER
M 12-5271	--	UNIVERSAL OPEN BARRELL CRIMPER
OB-1026	16-30	OPEN BARREL CRIMPER
OB-1028	14-24	OPEN BARREL CRIMPER
M 12-9500	16-22	METRIPACK - NO SEAL CRIMPER
GM 6285847	10-12	FASTON CRIMPER
M 3126 CT	16-30	SMALL UNIVERSAL CRIMPER

Extractors

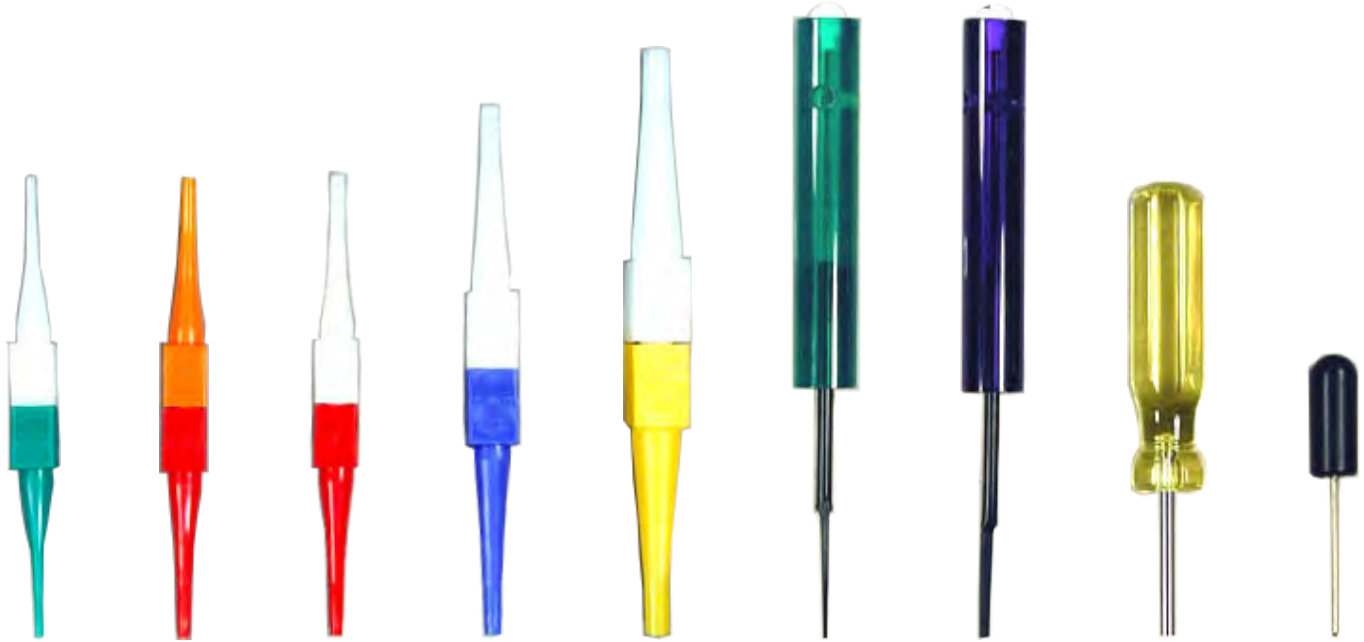

<i>Item Number</i>	<i>Size (GA)</i>	<i>Description</i>
MS M81969/14-01	MICRO	AUTOSPORT EXTRACTOR
MS M81969/14-10	22	AUTOSPORT EXTRACTOR
MS M81969/14-11	20	MILSPEC EXTRACTOR
MS M81969/14-03	16	MILSPEC EXTRACTOR
MS M81969/14-04	12	MILSPEC EXTRACTOR
M 12-4429	--	GREEN EXTRACTOR
M 12-4430	--	BLUE EXTRACTOR
EXWP	--	WEATHERPACK EXTRACTOR
M 12-1876	--	LK-TYPE TERMINAL EXTRACTOR

Boots

Rubber



Item Number	Description
RB 290	90° FOR LK-2 CONNECTOR
RB 4972	STRAIGHT FOR LK-2 CONNECTOR
RB 390	90° FOR LK-3/LK-4/LK-5 CONNECTOR
RB 3	STRAIGHT FOR LK-3/LK-4/LK-5 CONNECTOR
RB 6	STRAIGHT FOR LK-6 CONNECTOR
RB 7	STRAIGHT FOR LK-7 CONNECTOR
M 1558	BELLOW FOR MATING CONNECTORS OF DASHES
3605	BUSHING FOR MS AS616-26SN/MS AS616-35SN
3606	BUSHING FOR MS AS618-35SN
3607	BUSHING FOR MS AS614-35SN



Vinyl



Item Number	Description
M DRC26-24BT	FITS MATING CONNECTORS OF EXPANSION BOXES
M DRC40-BT	STRAIGHT FOR MATING CONNECTORS OF MOST ECU's
M DRC40-BT-90	90° FOR MATING CONNECTORS OF MOST ECU's

Connector Kits

MAP Sensor



Item Number	Description	Color
M 120-5796K	GM STYLE 200/300 KPA MAP	BLACK
M 120-5800K	GM STYLE 108 KPA BARO	BLUE
M 120-0403K	GM STYLE 100 KPA MAP	GREEN

MAP Sensor Connector Colors

The standard colors which are used with GM type MAP sensor connectors tells you which type of sensor it is.

For example:

Green connector 1 BAR MAP

Blue connector 108 KPA BARO

Black connector 2-3 BAR MAP

2 and 3 BAR MAP Sensors both have the same keying on the connector and can be easily interchanged as long as the calibration in the ECU is changed to match the sensor being used.

Weather-Pack

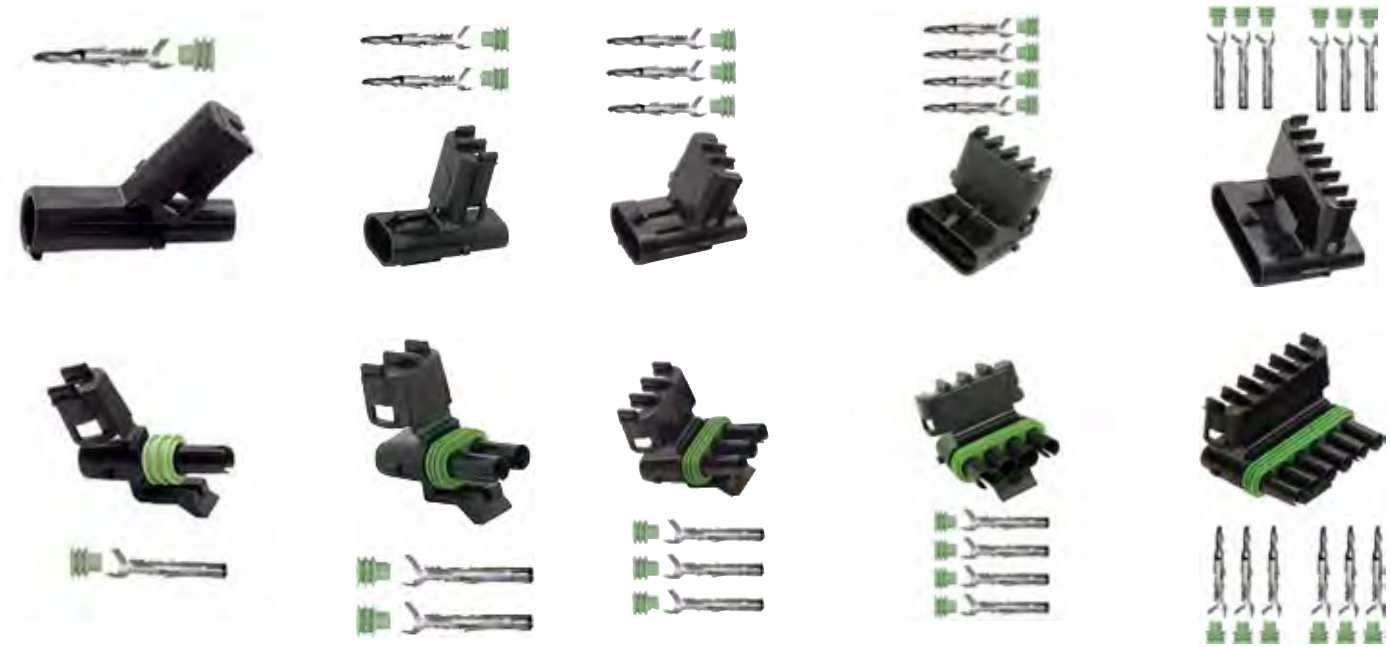

Item Number	Pin	Description
M 120-5791K	1	MALE HOUSING
M 120-5792K	2	MALE HOUSING
M 120-5793K	3	MALE HOUSING
M 120-5797K	4	MALE HOUSING
M 120-5799K	6	MALE HOUSING
M 120-0996K	1	FEMALE HOUSING
M 120-0973K	2	FEMALE HOUSING
M 120-0717K	3	FEMALE HOUSING
M 120-0974K	4	FEMALE HOUSING
M 120-0975K	6	FEMALE HOUSING

A word about Weatherpack

The Delphi Weatherpack series of connectors can be used with wire sizes ranging from 12 Ga to 20 Ga. There are corresponding seal sizes and terminal sizes to match the wire size. Before placing your order make sure which sizes you will require so that we can incorporate the proper sized terminals and seals into your order for you.

Metripack



Item Number	Pins	Color	
		Connector/Seal	Description
M 12-2641K	2	BLACK/GRAY	MALE BOOST VALVE KIT
M 12-7937K	8	BLACK/ORANGE	MALE HOUSING KIT
M 122-2193K	2	BLACK/LT BLUE	GM ENGINE TEMP KIT
M 15-7275K	3	BLACK/PURPLE	PSI TRANSDUCER KIT
M 12-2000K	2	-	FEMALE HOUSING KIT
M 12-7931K	8	-	FEMALE HOUSING KIT
M 122-2197K	2	GREY/LT BLUE	GM AIR TEMP KIT
M 15-9568K	4	BLK/WHT/LT BLUE	L2 & L7 COIL KIT

Pull to Seat Style

The Delphi pull to seat style connectors such as those used for Engine Temp and Air Temp and IAC require that you cut the wires longer than needed. You then insert the wires through the connector and terminate with the wire sticking through the front of the connector. Then - as the name implies - you pull the wires back into the connector until the terminal seats itself.

Miscellaneous

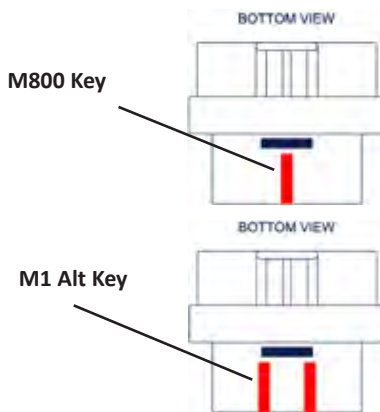

<i>Item Number</i>	<i>Pins</i>	<i>Color</i> <i>Connector/Seal</i>	<i>Description</i>
M 90980-11162K	2	BLACK/BROWN	TOYOTA VVT KIT
M 90980-11885K	4	BLACK/BLACK	TOYOTA COIL KIT
M 6189-0039K	2	GRAY/BLACK	NISSAN/TOYOTA INJECTOR KIT
M 14A464 K	2	BLACK/BLACK	FORD COBRA, LS-2/LS-7 INJECTOR KIT
M 12-7023K	2	GRAY/RED	TOYOTA REF/SYNC KIT
M 12-4669K	6	BLACK/GRAY	LSU 4.9 KIT
M800 ECU CONN	60	--	HUNDRED SERIES ECU CONNECTOR KIT
M1 ALT KEY CONN KIT	60	--	M1 SERIES ALT KEY CONN KIT

Bosch Sensor Kits



Item Number	Pins	Description
M LK-2 KIT	2	FEMALE HOUSING KIT
M LK-3 KIT	3	FEMALE HOUSING KIT
M LK-4 KIT	4	FEMALE HOUSING KIT
M LK-5 KIT	5	FEMALE HOUSING KIT
M LK-7 KIT	7	FEMALE HOUSING KIT
M LSU TERM	6	LSU SENSOR KIT
M LAMBDA KIT	-	LAMBDA SENSOR KIT

Injector Kits



<i>Item Number</i>	<i>Pins</i>	<i>Description</i>
M 4CYLK	4	INJECTOR KIT WITH STRAIGHT BOOTS
M 6CYLK	6	INJECTOR KIT WITH STRAIGHT BOOTS
M 8CYLK	8	INJECTOR KIT WITH STRAIGHT BOOTS
M 4CYLK-90	4	INJECTOR KIT WITH 90° BOOTS
M 6CYLK-90	6	INJECTOR KIT WITH 90° BOOTS
M 8CYLK-90	8	INJECTOR KIT WITH 90° BOOTS

DTM Kits

DTM connectors feature 20 AWG MilSpec contacts in plastic housings.



Item Number	Pins	Description
M DTM-2SK	2	FEMALE HOUSING KIT
M DTM-3SK	3	FEMALE HOUSING KIT
M DTM-4SK	4	FEMALE HOUSING KIT
M DTM-6SK	6	FEMALE HOUSING KIT
M DTM-8SK	8	FEMALE HOUSING KIT
M DTM-12SK	12	FEMALE HOUSING KIT



Item Number	Pins	Description
M DTM-2PK	2	MALE HOUSING KIT
M DTM-3PK	3	MALE HOUSING KIT
M DTM-4PK	4	MALE HOUSING KIT
M DTM-6PK	6	MALE HOUSING KIT
M DTM-8PK	8	MALE HOUSING KIT
M DTM-12PK	12	MALE HOUSING KIT

DT/DTP Kits

DT connectors feature 16 AWG MilSpec contacts in plastic housings.



Item Number	Pins	Description
M DT-2SK	2	FEMALE HOUSING KIT
M DT-4SK	4	FEMALE HOUSING KIT
M DT-6SK	6	FEMALE HOUSING KIT
M DT-12SK	12	FEMALE HOUSING KIT

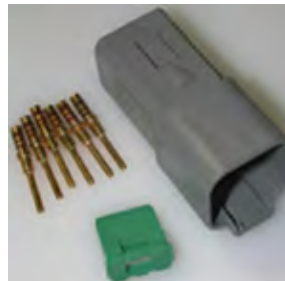

Item Number	Pins	Description
M DT-2PK	2	MALE HOUSING KIT
M DT-4PK	4	MALE HOUSING KIT
M DT-6PK	6	MALE HOUSING KIT
M DT-12PK	12	MALE HOUSING KIT



Item Number	Pins	Description
M DTP-2PK	2	MALE HOUSING KIT
M DTP-2SK	2	FEMALE HOUSING KIT
M DTP-4PK	4	MALE HOUSING KIT
M DTP-4SK	4	FEMALE HOUSING KIT

Autosport Connectors

Type 0 Micro Series

RECEPTACLE - TYPE 0 & 2

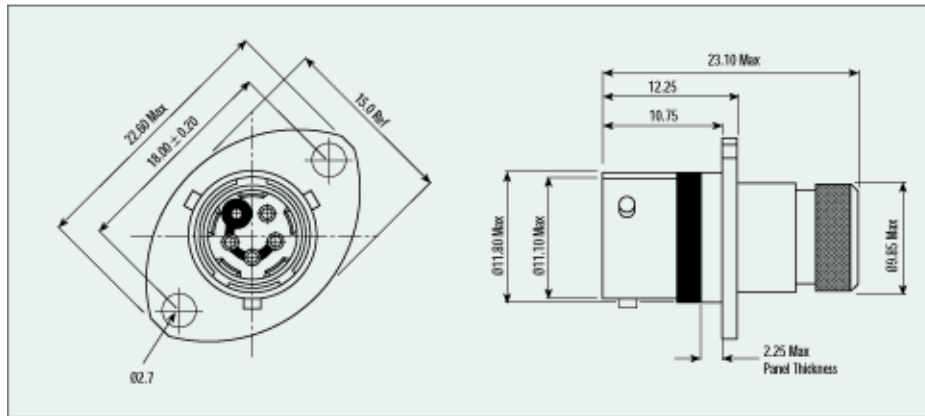

Specifications

Standard Connector

Connector comes with pins/sockets and an insertion/extraction tool

Materials

Shell/Coupling ring:
High Strength Aluminium alloy
Black Zinc finish

Contacts:

Copper alloy
Gold plated

Insulators:

Thermoplastic

Interface/Wire seals:

Fluorinated silicone

Features

Compact Design
Cable accommodation - 22, 24, 26, & 28 AWG
Locking coupling mechanism
Black zinc finish
Interfacial and wire sealing
Integral screen/boot termination feature
In-line and two hole mounting styles
Gold-plated crimp contacts
5 Keyway orientations
Universal orientation for test equipment (Plug type 6 only)

Item Number	Contact Type	Key Color
MS ASL006-05PA	PIN	YELLOW
MS ASL006-05PB	PIN	BLUE
MS ASL006-05PC	PIN	ORANGE
MS ASL006-05PD	PIN	GREEN
MS ASL006-05PN	PIN	RED
MS ASL006-05SA	SOCKET	YELLOW
MS ASL006-05SB	SOCKET	BLUE
MS ASL006-05SC	SOCKET	ORANGE
MS ASL006-05SD	SOCKET	GREEN
MS ASL006-05SN	SOCKET	RED

Type 1 Micro Series

INLINE RECEPTACLE – TYPE 1

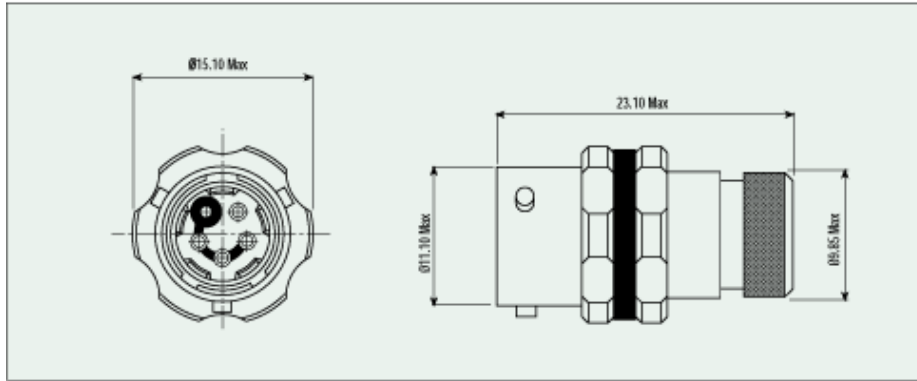

Item Number	Contact Type	Key Color
MS ASL106-05PA	PIN	YELLOW
MS ASL106-05PC	PIN	ORANGE
MS ASL106-05PD	PIN	GREEN
MS ASL106-05PN	PIN	RED
MS ASL106-05SA	SOCKET	YELLOW
MS ASL106-05SB	SOCKET	BLUE
MS ASL106-05SC	SOCKET	ORANGE
MS ASL106-05SD	SOCKET	GREEN
MS ASL106-05SN	SOCKET	RED

Specifications

Standard Connector

Connector comes with pins/sockets and an insertion/ extraction tool

Materials

Shell/Coupling ring:
High Strength Aluminium alloy
Black Zinc finish

Contacts:

Copper alloy
Gold plated

Insulators:

Thermoplastic

Interface/Wire seals:

Fluorinated silicone

Features

Compact Design
Cable accommodation - 22, 24, 26, & 28 AWG
Locking coupling mechanism
Black zinc finish
Interfacial and wire sealing
Integral screen/boot termination feature
In-line and two hole mounting styles
Gold-plated crimp contacts
5 Keyway orientations
Universal orientation for test equipment (Plug type 6 only)

Type 6 Micro Series

PLUG – TYPE 6

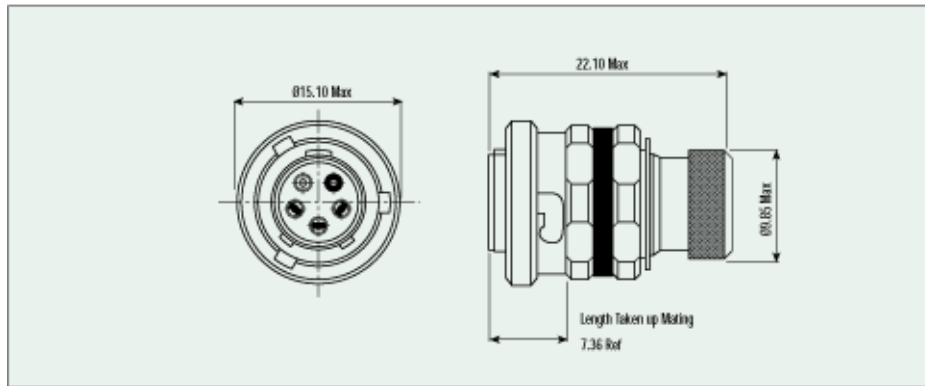

Specifications

Standard Connector

Connector comes with pins/sockets and an insertion/ extraction tool

Materials

Shell/Coupling ring:
High Strength Aluminium alloy
Black Zinc finish

Contacts:

Copper alloy
Gold plated

Insulators:

Thermoplastic

Interface/Wire seals:

Fluorinated silicone

Features

Compact Design
Cable accommodation - 22, 24, 26, & 28 AWG
Locking coupling mechanism
Black zinc finish
Interfacial and wire sealing
Integral screen/boot termination feature
In-line and two hole mounting styles
Gold-plated crimp contacts
5 Keyway orientations
Universal orientation for test equipment (Plug type 6 only)

Item Number	Contact Type	Key Color
MS ASL606-05PA	PIN	YELLOW
MS ASL606-05PB	PIN	BLUE
MS ASL606-05PC	PIN	ORANGE
MS ASL606-05PD	PIN	GREEN
MS ASL606-05PN	PIN	RED
MS ASL606-05PU	PIN	GREY
MS ASL606-05SA	SOCKET	YELLOW
MS ASL606-05SB	SOCKET	BLUE
MS ASL606-05SC	SOCKET	ORANGE
MS ASL606-05SD	SOCKET	GREEN
MS ASL606-05SN	SOCKET	RED
MS ASL606-05SU	SOCKET	GREY

Type 0 AS Series

RECEPTACLE – TYPE 0

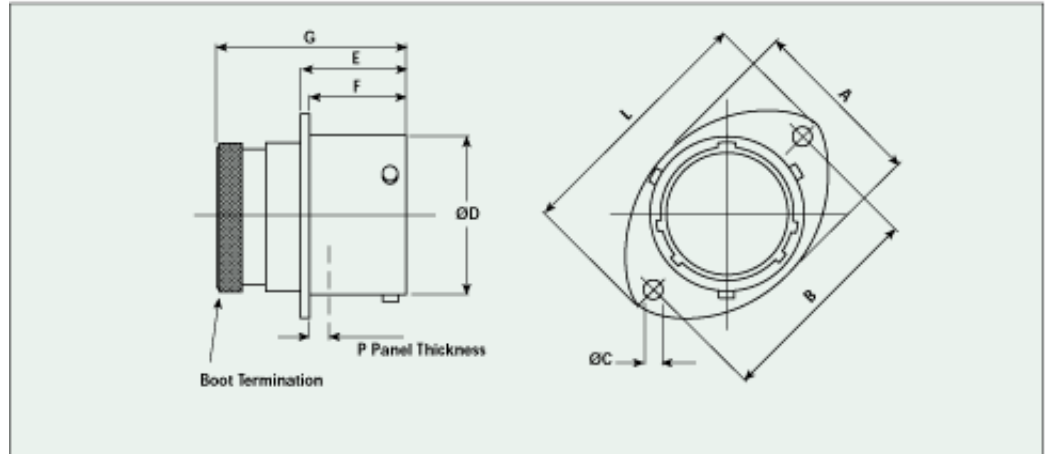

Item Number	Contact Type	Number Of Contacts			
		Size 16	Size 20	Size 22	Key Color
MS AS008-35PN	PIN			6	RED
MS AS008-35SN	SOCKET			6	RED
MS AS010-35PN	PIN			13	RED
MS AS010-35SN	SOCKET			13	RED
MS AS010-98SN	SOCKET		6		RED
MS AS012-35PN	PIN			22	RED
MS AS012-35SN	SOCKET			22	RED
MS AS012-98SN	SOCKET		10		RED
MS AS014-19PN	PIN		19		RED
MS AS014-19SN	SOCKET		19		RED
MS AS014-35SN	SOCKET			37	RED
MS AS016-26PN	PIN		26		RED
MS AS016-26SN	SOCKET		26		RED
MS AS016-35PN	PIN			55	RED
MS AS016-35SN	SOCKET			55	RED
MS AS018-35PN	PIN			66	RED
MS AS022-21SN	SOCKET	21			RED

Specifications

Standard Connector

Connector comes with pins/sockets and an insertion/extraction tool

Materials

Shell/Coupling ring:
High Strength Aluminium alloy
Black Zinc finish

Contacts:

Copper alloy
Gold plated

Insulators:

Thermoplastic

Interface/Wire seals:

Fluorinated silicone

Features

High Density arrangements up to 128 ways
Three contact sizes: 16, 20, and 22 AWG
Locking coupling mechanism
Black zinc finish
Interfacial and wire sealing
Integral screen/boot termination feature
In-line and two hole mounting styles
Gold-plated crimp contacts
Filter, Hermetic, and Fiber Optic options available
Universal orientation for test equipment (Plug type 6 only)

Type 1 AS Series

INLINE RECEPTACLE – TYPE 1

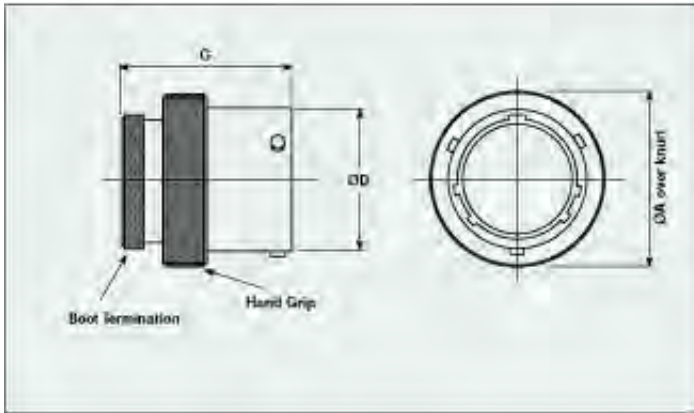

Specifications

Standard Connector

Connector comes with pins/sockets and an insertion/ extraction tool

Materials

Shell/Coupling ring:
High Strength Aluminium alloy
Black Zinc finish

Contacts:

Copper alloy
Gold plated

Insulators:

Thermoplastic

Interface/Wire seals:

Fluorinated silicone

Features

High Density arrangements up to 128 ways
Three contact sizes: 16, 20, and 22 AWG
Locking coupling mechanism
Black zinc finish
Interfacial and wire sealing
Integral screen/boot termination feature
In-line and two hole mounting styles
Gold-plated crimp contacts
Filter, Hermetic, and Fiber Optic options available
Universal orientation for test equipment (Plug type 6 only)

Item Number	Contact Type	Number Of Contacts			
		Size 16	Size 20	Size 22	Key Color
MS AS108-35PN	PIN			6	RED
MS AS108-35SN	SOCKET			6	RED
MS AS110-35PA	PIN			13	YELLOW
MS AS110-35PN	PIN			13	RED
MS AS110-35SN	SOCKET			13	RED
MS AS110-98PN	PIN		6		RED
MS AS112-35PN	PIN			22	RED
MS AS112-35SN	SOCKET			22	RED
MS AS112-98SN	SOCKET		10		RED
MS AS114-35PN	PIN			37	RED
MS AS114-35SN	SOCKET			37	RED
MS AS116-26PN	PIN		26		RED
MS AS118-35PN	PIN			66	RED

Type 2 AS Series

PCB BOX MOUNTING RECEPTACLE – TYPE 2

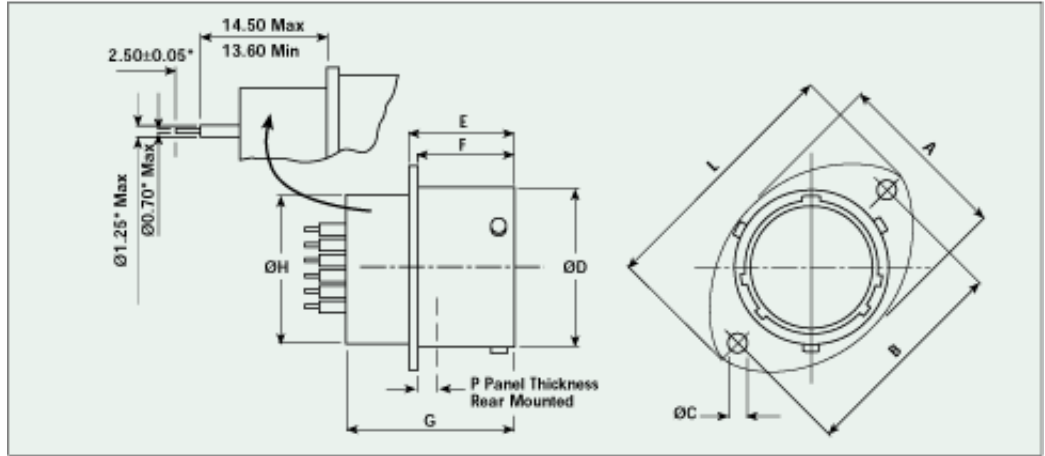

*Dimensions for 20 and 22 contacts shown are for standard parts. Other PCB contacts are available.

Item Number	Contact Type	Number Of Contacts			
		Size 16	Size 20	Size 22	Key Color
MS AS208-35PN	PIN			6	RED
MS AS208-35SN	SOCKET			6	RED
MS AS210-35PA	PIN			13	YELLOW
MS AS210-35PN	PIN			13	RED
MS AS210-35SN	SOCKET			13	RED
MS AS212-35PN	PIN		6		RED
MS AS212-35SN	SOCKET			22	RED

Specifications

Standard Connector

Connector comes with pins/sockets and an insertion/extraction tool

Materials

Shell/Coupling ring:
High Strength Aluminium alloy
Black Zinc finish

Contacts:

Copper alloy
Gold plated

Insulators:

Thermoplastic

Interface/Wire seals:

Fluorinated silicone

Features

High Density arrangements up to 128 ways
Three contact sizes: 16, 20, and 22 AWG
Locking coupling mechanism
Black zinc finish
Interfacial and wire sealing
Integral screen/boot termination feature
In-line and two hole mounting styles
Gold-plated crimp contacts
Filter, Hermetic, and Fiber Optic options available
Universal orientation for test equipment (Plug type 6 only)

Type 6 AS Series

PLUG - TYPE 6

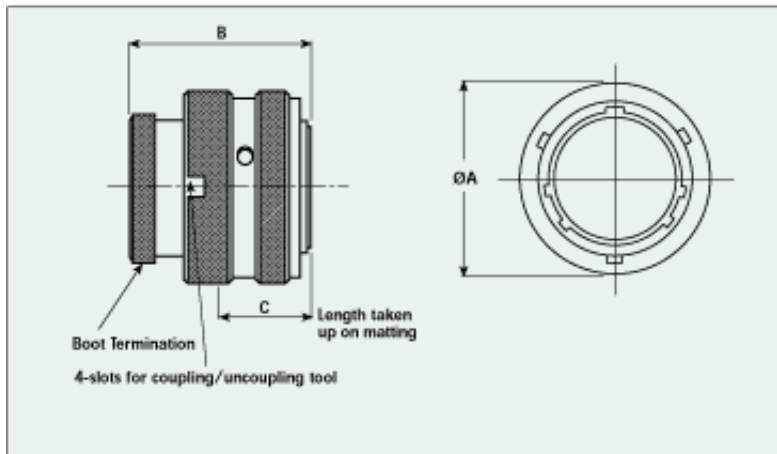

Specifications

Standard Connector

Connector comes with pins/sockets and an insertion/extraction tool

Materials

Shell/Coupling ring:
High Strength Aluminium alloy
Black Zinc finish

Contacts:

Copper alloy
Gold plated

Insulators:

Thermoplastic

Interface/Wire seals:

Fluorinated silicone

Features

High Density arrangements up to 128 ways
Three contact sizes: 16, 20, and 22 AWG
Locking coupling mechanism
Black zinc finish
Interfacial and wire sealing
Integral screen/boot termination feature
In-line and two hole mounting styles
Gold-plated crimp contacts
Filter, Hermetic, and Fiber Optic options available
Universal orientation for test equipment (Plug type 6 only)

Item Number	Contact Type	Number Of Contacts			
		Size 16	Size 20	Size 22	Key Color
MS AS608-35PN	PIN			6	RED
MS AS608-35SN	SOCKET			6	RED
MS AS610-35PN	PIN			13	RED
MS AS610-35SA	SOCKET			13	YELLOW
MS AS610-35SN	SOCKET			13	RED
MS AS610-98PN	PIN		6		RED
MS AS610-98SN	SOCKET		6		RED
MS AS612-35PN	PIN			22	RED
MS AS612-35SN	SOCKET			22	RED
MS AS612-98PN	PIN		10		RED
MS AS614-19PN	PIN		19		RED
MS AS614-19SN	SOCKET		19		RED
MS AS614-35PN	PIN			37	RED
MS AS614-35SN	SOCKET			37	RED
MS AS616-26PN	PIN		26		RED
MS AS616-26SN	SOCKET		26		RED
MS AS616-35PN	PIN			55	RED
MS AS616-35SA	SOCKET			55	YELLOW
MS AS616-35SN	SOCKET			55	RED
MS AS618-35PN	PIN			66	RED
MS AS618-35SN	SOCKET			66	RED
MS AS620-16PN	PIN	16			RED
MS AS620-35SN	SOCKET			79	RED
MS AS622-21PN	PIN	21			RED

Apparrel



Item Number	Size	Description
MOTEC HAT BLACK	S/M	BLACK WITH RED MOTEC LOGO ON FRONT - WEBSITE ON BACK
	L/XL	
MOTEC T-SHIRT	S	BLACK WITH RED MOTEC LOGO AND WEBSITE ON BACK
	M	
	L	
	XL	
	XXL	

Support

On-Site

MoTeC personnel are ready to travel to your location anywhere in the world to offer technical assistance—or we'll help you by phone, fax, and email. Ask us about our annual training seminars. Fees are charged per day (minimum of one day) payable to technician upon arrival at the site. Fees are charged per day / travel (minimum of 2 days) payable in advance. Call for a quote on transportation, meals, and lodging.



Phone

Fees are charged per hour (billed in 60-minute increments)



Track

Fees are charged per yearly subscription.



Online Help Files

MoTeC USA has begun placing HTML based help on our website for our customers. Visit www.motec.com and click the link to support to gain access to our help files.

Glossary

Sequential Fuel Injection

Sequential means that each injector for each cylinder is triggered only one time during the engine's cycle. Typically the injector is triggered only during the intake stroke. True sequential injection requires the ECU to know not only where top dead center is, but also which half of the cycle the engine is on. TDC on a 4 stroke occurs 2 times during the cycle, once on compression and once on exhaust. MoTeC references all timing events that occur within the ECU, to Top Dead Center Compression. This generally requires an input on the engine's camshaft to provide the ECU with a SYNC signal. Once the ECU is synched, injection timing can be optimized to provide the most efficient mixing of fuel and air into the cylinder. Control of injection timing can lead to increases in midrange torque while decreasing emissions and fuel consumption.

Semi-Sequential Fuel Injection

Semi-Sequential means that 2 or more cylinder's injectors are triggered at the same time, but only 1 time during the engine's cycle. This requires the ECU to be synched with the engine's cycle. Typically injection timing is retarded from the optimum timing point for full sequential by an angle which is equal to 1/2 the angle between 2 cylinders in crankshaft degrees. On a V8 Chevrolet, the injectors for cylinders 1 and 8 would be triggered at the same time. They would be triggered 45 degrees late for cylinder number 1 and 45 degrees early for cylinder number 8. Degrees between 1 and 8 = 90 ; 1/2 of 90 = 45. Semi-sequential allows optimization of injection timing which typically leads to increases in midrange torque and a reduction in fuel consumption for equivalent power compared which Batch fire.

Injection Timing

With a synched engine which uses 1 injector in each intake manifold runner, it is possible to phase the firing of the injector so that it only sprays during the intake stroke. This allows you to introduce fuel into the intake stream precisely at the time when the airflow into the cylinder is the greatest providing the best possible atomization and the highest efficiency. MoTeC offers a user definable 2 or 3 dimensional Injection Timing adjustment table so that you can accurately match any engine's injection timing demands. Tuners can select either beginning or end of injection on which to base the timing table. This allows the tuner the ultimate in adjustability to suit any engine combination. With the M4 and M48 ECU's Injection timing is adjustable in 5 degree increments while the M400/600/800 Series offer .1 degree resolution making them suitable for Gasoline or Diesel Direct Injection.

Batch Fire

Batch fire means that 2 or more injectors are triggered at the same time once every crankshaft revolution. If the ECU is synched with the engine's cycle, the injection timing can only be half optimized as fuel is injected both on the intake stroke and on the power stroke. Companion cylinders are paired in batch fire mode similar to wasted spark ignition modes. The advantage of batch firing is that the ECU needs only to know where TDC is. This means that a sync on the cam is not required. The disadvantage to batch firing is that the Injector Dead Time is doubled for the engine's cycle. This leads to a decrease in fuel flow and typically requires a larger, less efficient injector to be used to make up for the loss of flow. On High Horsepower applications this means the idle quality will suffer tremendously.

Injector Dead Time

Injector dead time refers to the latency of the injector in producing maximum flow rate. All injectors require a certain amount of time to open completely and produce maximum flow. The amount of time is dependant on several variables including; fuel pressure, battery voltage and physical characteristics of the injectors themselves. Typically higher fuel pressure or lower battery voltage tends to increase the dead time. This leads to a reduction in fuel flow in to the engine and as a result influences the engine's state of tune. Luckily MoTeC allows the user to define an injector Dead Time table if the values are known, or use a standard compensation which is known for a number of injectors. The ECU automatically adjusts the values as the battery voltage changes to ensure that the fuel curve remains constant. If a fuel pressure input is used on the system, MoTeC can compensate for variations in fuel pressure to achieve a consistent fueling even with varying fuel pressures.

4 Wire Wide Band Lambda Sensor

This technology takes advantage of the fact that a 4 Wire Wide Band Lambda sensor's voltage output is based on not only the oxygen differential between the exhaust pipe and atmosphere, but also is dependant on the temperature of the sensor itself. Sensor impedance varies with temperature, so a MoTeC ECU measures not only Wide Band Lambda Voltage, but also the sensor impedance. It is not possible to properly display lambdas without monitoring the sensor temperature. Systems which do not use at least a 4 wire sensor typically have errors in displayed lambda as high as 8%!

5 Wire Wide Band Lambda Sensor

This newer technology is used to determine the air fuel ratio of an engine by measuring lambda sensor output and measuring the current required to hold the sensor voltage output constant. An oxygen sensor produces voltage and a small amount of current as oxygen atoms pass across its substrate from high concentration to low concentration. The greater the flow of oxygen, the greater the voltage produced. This is the case when a rich mixture is encountered. Conversely, when current is applied to an oxygen sensor, oxygen atoms are moved from a low concentration to a high concentration or vice versa depending on the polarity of the current applied. The MoTeC M400/600/800/880 ECU's are capable of measuring this type of sensor input which offers increased speed and accuracy over the older technology 4 wire sensors. M4 and M48 ECU's can leverage the 5 wire technology by connecting a MoTeC PLM, which has a definable analog voltage output, to the Lambda input on the ECU.

What is Lambda?

Lambda describes an equivalence value in percentage of the chemically correct air-to-fuel ratio for any type of fuel. If the air fuel ratio measured in the exhaust pipe of an engine is at the chemically correct (stoichiometric) ratio of air-to-fuel, lambda is equal to 1.0. In the case of gasoline, lambda 1.0 is equivalent to 14.7:1 air-to-fuel. Lambdas less than 1.0 indicate the engine is running richer than stoichiometric, while lambdas greater than 1.0 indicate a lean mixture. If we measure a lambda value of 1.06 and we want a lambda value of .95, we simply increase the fuel delivered to the engine (pulsewidth) by 11 percent. This will place us exactly at .95 lambda. By using the Lambda Was or the Quick Lambda functions a tuner can quickly shape the fuel table to match the engine's exact requirements. In addition, the W Lambda function copies the Quick Lambda value to the sites immediately to the right and up above to help keep the fuel table variance from one site to another at a minimum.

Bosch LSU and NTK UEGO Sensors

Both the MoTeC M400/600/800/880 and the MoTeC PLM are capable of operating with either the NTK UEGO or the Bosch LSU-4 5 wire wide band sensors. Of the two, the NTK is most accurate. It is a true laboratory grade sensor. Its accuracy has been found to be about 1.5% better than that of the Bosch LSU. Additionally the NTK has a better response time than does the LSU again about 1.5%. The NTK is the benchmark against which the LSU is measured. The advantage of the LSU sensor is its lower price compared to the NTK. If you are doing very precise and accurate laboratory type testing, the NTK is the sensor for you. Both sensors have a life expectancy of 500 hours on unleaded fuels and that number is diminished to 50 hours using leaded fuels. Lambda Sensors are very similar to spark plugs with respect to their estimated life expectancy. Spark Plugs are designed to last 40,000 miles under optimum circumstances but they can be damaged in less than 1 mile by misuse. A lambda sensor can be thought of the same way. Misuse by overly rich mixtures, high temperatures, overtightening or dropping can have a very negative effect on lambda sensor life. Like spark plugs, lambda sensors cannot be returned under warranty.

Quick Lambda and Lambda Was

A MoTeC ECU, allows the user to define a lambda goal table based on load and rpm. The Quick Lambda function in the software allows a tuner to quickly adjust the values in the fuel control table to achieve the goal lambda, based on the lambda reported by the sensor. If the reported lambda is .98 and the goal is .93, the ECU automatically jumps to the current load site, and multiplies the value in the site by 1.05. The next time the engine runs in that site, the lambda will be .93. Similarly, Lambda Was allows a user to locate a load and rpm site in the main fuel table and enter a recorded lambda measurement from a data log. The ECU multiplies the load site value by the difference between entered lambda and the goal lambda value so that the engine will achieve the goal lambda the next time it runs on that load site. This makes tuning much faster and easier than calculating the required enrichment based on an air fuel ratio number. Of course you can manually do multiplication, division, addition and or subtraction on any site or a number of sites with only a few keystrokes, and the overall trim function allows you to trim the entire fuel or ignition table up or down based on percentage.

CDI-8 Ignition

Capacitive Discharge Ignition has been used in racing and in some automobiles for a number of years. MoTeC offers one of the industry's most advanced capacitive discharge ignition systems available. The CDI-8 is an 8 channel CD Ignition which can either run in stand alone mode (meaning it does not require an ECU to run it) or in slave mode. In slave mode, the CDI-8 receives an encoded signal from a MoTeC ECU which tells it which coil output to fire. In this mode, a CDI-8 can deliver a full energy spark at up to 1.1KHz which is enough to keep up with an 8 cylinder engine turning 16,000 rpm!

MoTeC Software

Always free from www.motec.com New software upgrades will allow additional features for your ECU. Since each ECU is produced with all of the same hardware, there will never be an issue of a feature not working with an older ECU. New features will always work with every ECU.

Security

MoTeC offers its customers the option of securing their tuning file through two methods. The first is a simple password protection which can be set on the ECU so that others are not able to make changes to the tuning file nor can they send a new file to the ECU unless they have the password. The password can be reset as often as you like, and you may choose to turn the password off at anytime but you must know the password in order to perform these functions. Additionally, MoTeC allows the tuner to encrypt a file which is stored within the ECU. In this case, the file can only be sent to an ECU which has a matching password for the encrypted file. If file encryption is used, a tuner could send an encrypted file to a customer with a matching password, and the customer would be able to send the file to the ECU without knowing the password. The customer would still not be able to view or in anyway modify the file. Data downloads can always be retrieved whether or not a password is set on an ECU.

High/Low Injection Capability

On many types of racing engines, tuners may find improved efficiency by changing the physical location of the injector in relation to the intake valve. MoTeC allows the user to run 2 sets of injectors in the inlet path and switch from one to the other with a 3 dimensional table based on load and rpm. Typically this feature is used when an engine is making substantial amounts of horsepower but requires only small amounts of fuel at low speeds. In this case, the tuner can select 2 injectors of differing flow rates, one for low speed operation, the other for high speed/power operation. MoTeC allows you to define the flow differential between the 2 injectors, so that the proper amount of fuel can be delivered out of each injector. Another way to use the MoTeC High/Low capability, is to use 2 injectors of equal flow rate, but located at different points in the inlet path. In this manner, fuel injection location can be varied at certain points in the rpm band to provide the highest efficiency. Of course MoTeC allows you to enrich or enlean the engine at the transition from 1 set of injectors to the other to provide seamless operation.

Crank Index Position

The CRank index Position is perhaps the most important timing value in the ECU. The CRiP tells the ECU where the engine is in relation to TDC Cylinder #1. The CRiP is defined as the distance in crankshaft degrees, between the reference tooth when it is aligned with the crankshaft position sensor, and Top Dead Center Compression Number 1. For example, if the reference tooth is aligned with the crankshaft sensor when the crankshaft is 55 degrees before TDC Compression Number 1, then the CRiP is 55. An easy way to determine the CRiP before startup is to rotate the crankshaft in the direction of rotation until the reference tooth is aligned with the crankshaft position sensor. Then measure the number of degrees, required to turn the crankshaft in the direction of rotation until the number 1 cylinder is at Top Dead Center of the Compression stroke. Once you determine this value, you may start the engine and enter the CRiP set screen under the Ignition menu. Use a non dial-back timing light to check the CRiP. The timing advance displayed in the CRiP set screen should match the measured value using the timing light. If they do not match, move the CRiP value until the timing does match.

Reference Tooth

The definition of the Reference Tooth depends on the type of Ref/Sync mode being used. If using missing or extra tooth type modes, the reference tooth is defined as the tooth which occurs directly following the missing or extra tooth or teeth. If using 1 tooth per TDC or Multiple tooth mode with a sync input, the reference tooth is defined as the tooth which occurs directly following the sync input.